

CODE	NAME	Default/QTY.	Page No.
1	ReceptionStack_900D	1	
2	Skin_Board	1	
3	Skin_Cover	1	
4	Skin Storage	1	
5	Skin Storage	1	
6	Wrapping Drawer	1	
7	Printer Tray	1	
8	Printer	1	
9	Cash Register	1	
10	Cpu Rubbish Shelf	1	
11	DESKTOP PC_Seppeltsfield	1	
12	BubbleWrap	1	
13	Base_002	3	

NOTES:
 1. BALLOONED DIMENSIONS ARE CRITICAL INSPECTION DIMENSIONS
 2. DIMENSIONS IN PARENTHESIS ARE FOR REFERENCE ONLY (NON CRITICAL)
 3. ANY MODIFICATIONS FROM INITIAL APPROVED SAMPLE MUST BE SUBMITTED FOR APPROVAL
 4. DRAWING MUST BE APPROVED AND SIGNED PRIOR TO MANUFACTURE
 5. © THIS DRAWING IS OWNED BY AND IS ONLY TO BE USED WITH APPROVAL FROM UCI MANUFACTURING

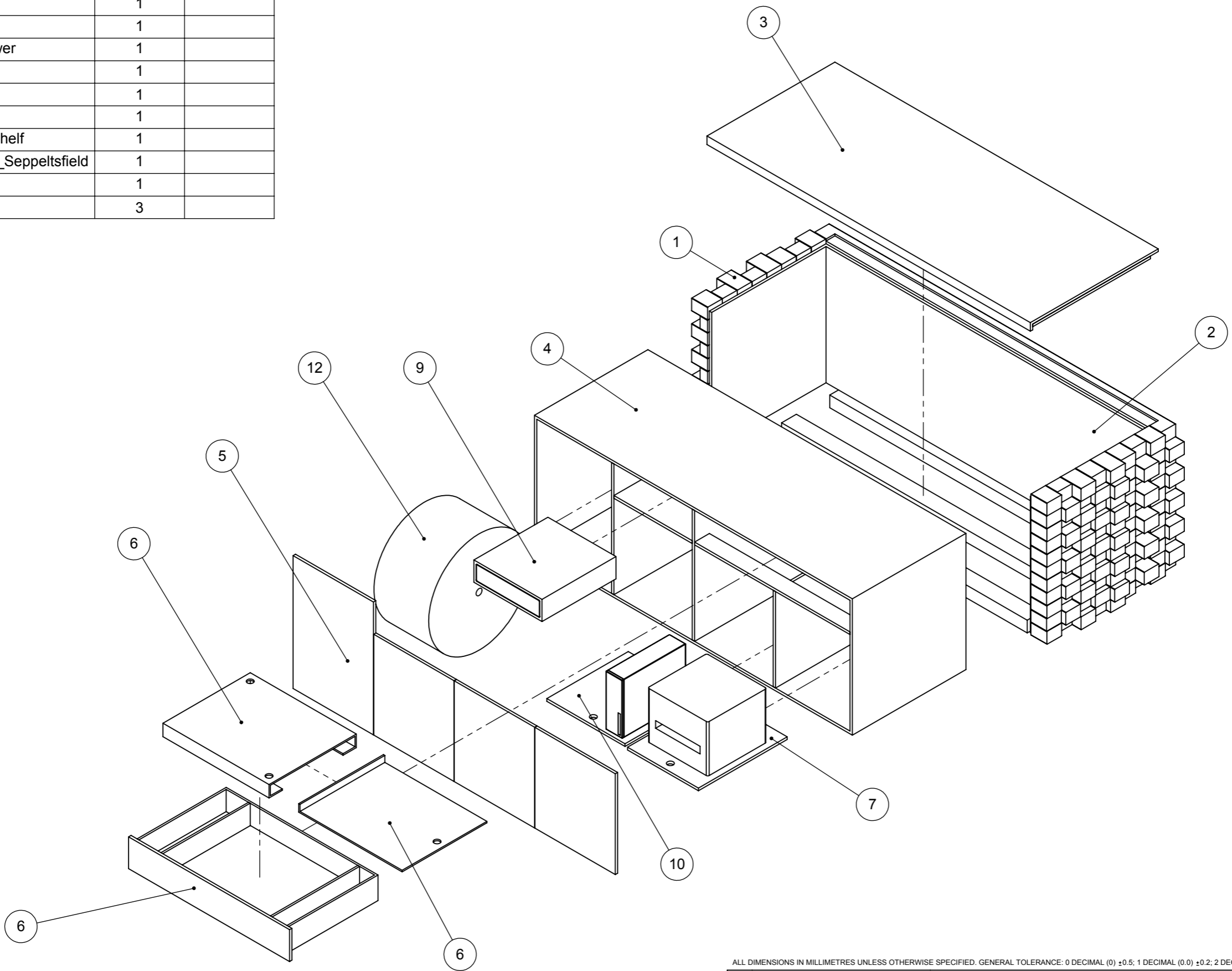

ALL DIMENSIONS IN MILLIMETRES UNLESS OTHERWISE SPECIFIED. GENERAL TOLERANCE: 0 DECIMAL (0) ±0.5; 1 DECIMAL (0.0) ±0.2; 2 DECIMALS (0.00) ±0.1; ANGLES ±0.5

DESCRIPTION						
SEPPELTSFIELD SHOWROOM						
DRAWN BY	DRAWN DATE	CLUSTER				
AG	10.09.13	COUNTER EXPLODED ASSEMBLY (VERSION 1 000 000)				
DO NOT SCALE DRAWING		SHEET	PAGE	SCALE	CODE	Rev
		A3	1 OF 13	1:20	N/A	1

- NOTES:
 1. BALLOONED DIMENSIONS ARE CRITICAL INSPECTION DIMENSIONS
 2. DIMENSIONS IN PARENTHESIS ARE FOR REFERENCE ONLY (NON CRITICAL)
 3. ANY MODIFICATIONS FROM INITIAL APPROVED SAMPLE MUST BE SUBMITTED FOR APPROVAL
 4. DRAWING MUST BE APPROVED AND SIGNED PRIOR TO MANUFACTURE
 5. © THIS DRAWING IS OWNED BY AND IS ONLY TO BE USED WITH APPROVAL FROM UCI MANUFACTURING

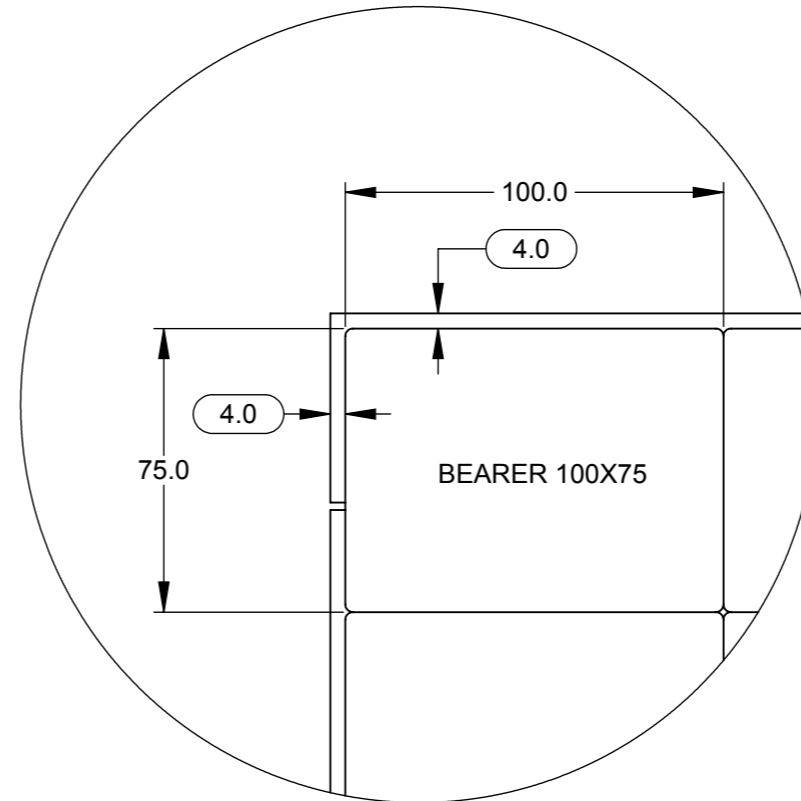
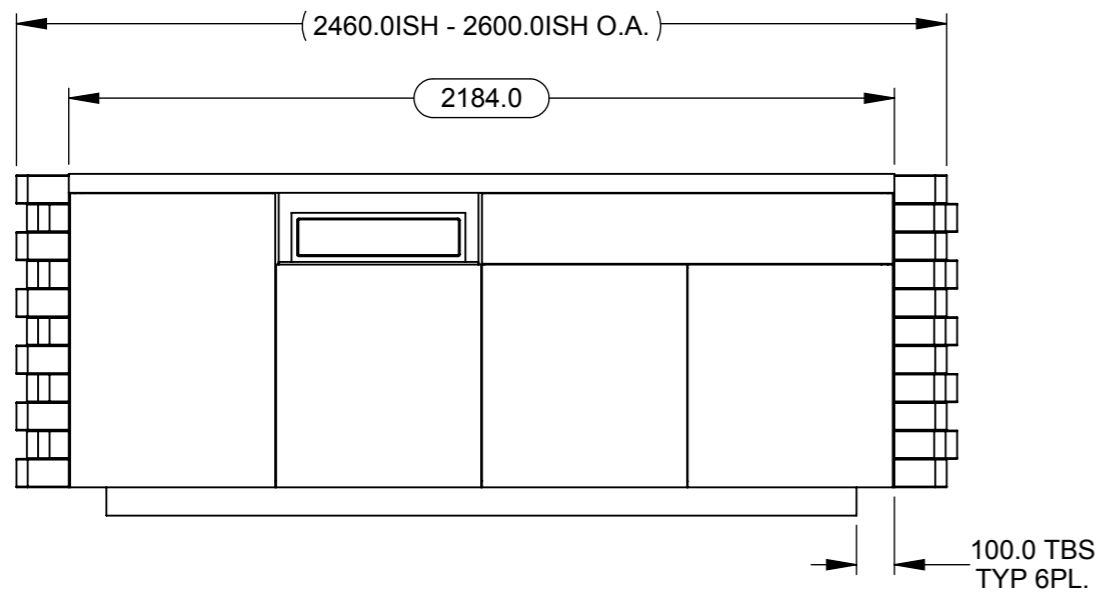
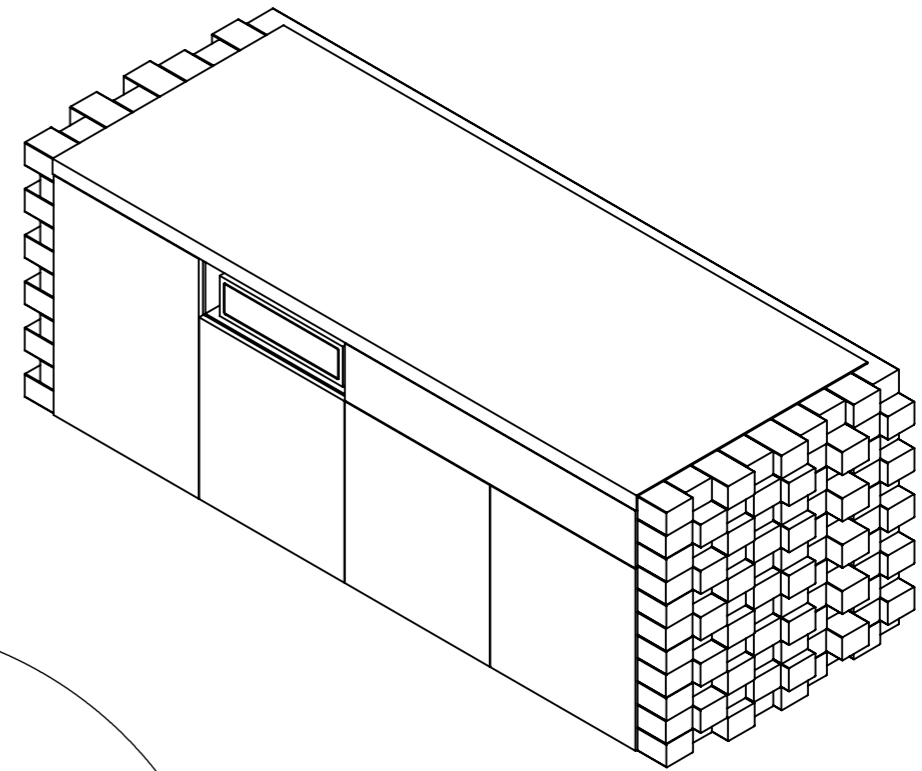
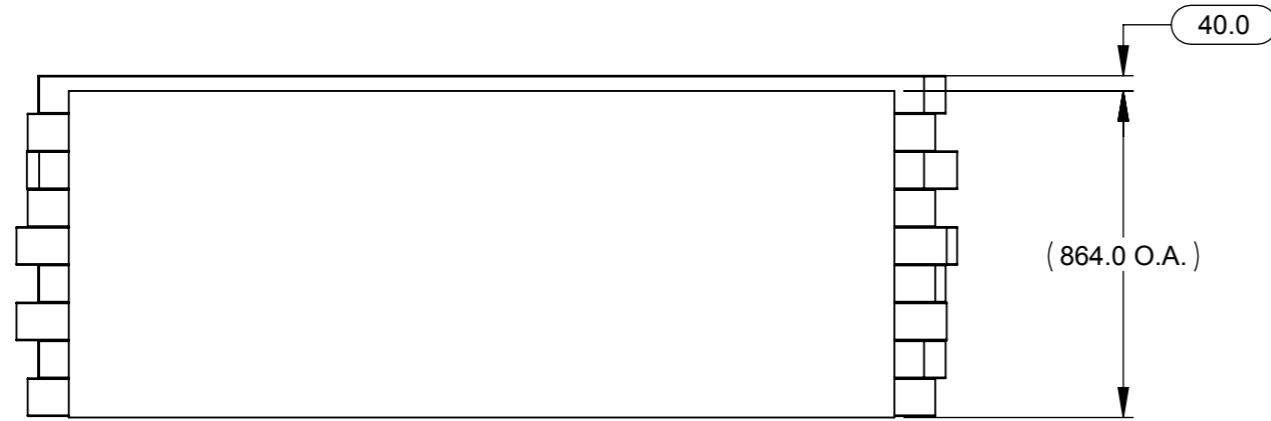

DETAIL A
 SCALE 1 : 2

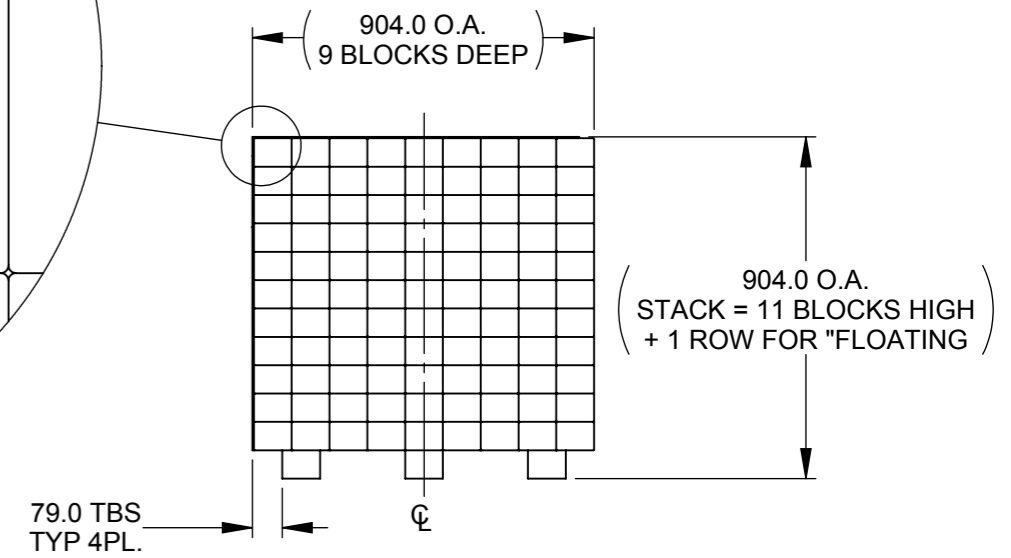

ALL DIMENSIONS IN MILLIMETRES UNLESS OTHERWISE SPECIFIED. GENERAL TOLERANCE: 0 DECIMAL (0) ±0.5; 1 DECIMAL (0.0) ±0.2; 2 DECIMALS (0.00) ±0.1; ANGLES ±0.5

DESCRIPTION						
SEPPELTSFIELD SHOWROOM						
DRAWN BY	DRAWN DATE	CLUSTER				
AG	10.09.13	COUNTER				
DO NOT SCALE DRAWING	SHEET	PAGE	SCALE	CODE	Rev	
	A3					2 OF 13

MATERIALS FINISH

CODE	ITEM	MATERIAL	FINISH
1	BLOCKS	RECLAIMED JARRAH	NATURAL / WIRE BRUSHED
2	SKIN BOARD	16mm BIRCH PLY	WHITENED EDGE + INTERNAL FACES / BLACK OUTSIDE FACE 10% CLEAR

NOTES:
 1. BALLOONED DIMENSIONS ARE CRITICAL INSPECTION DIMENSIONS
 2. DIMENSIONS IN PARENTHESIS ARE FOR REFERENCE ONLY (NON CRITICAL)
 3. ANY MODIFICATIONS FROM INITIAL APPROVED SAMPLE MUST BE SUBMITTED FOR APPROVAL
 4. DRAWING MUST BE APPROVED AND SIGNED PRIOR TO MANUFACTURE
 5. © THIS DRAWING IS OWNED BY AND IS ONLY TO BE USED WITH APPROVAL FROM UCI MANUFACTURING

NOTE
PANEL SIZE HEIGHT HAS BEEN DETERMINED BY:

12MM STRINGERS SCREW FIXED TO THE TOP EDGE OF THE SIDE PANELS.

THIS WILL GIVE A 4mm OFFSET TO THE TOP FACE OF THE 16mm BIRCH PLY PANEL, THE "SKIN COVER"

INSTRUCTIONS FOR LEVELING BEARERS (SCALE 1:10)

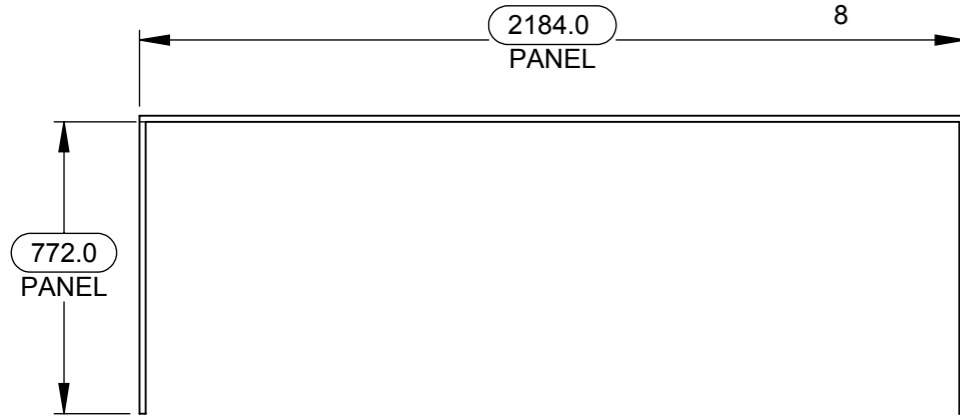
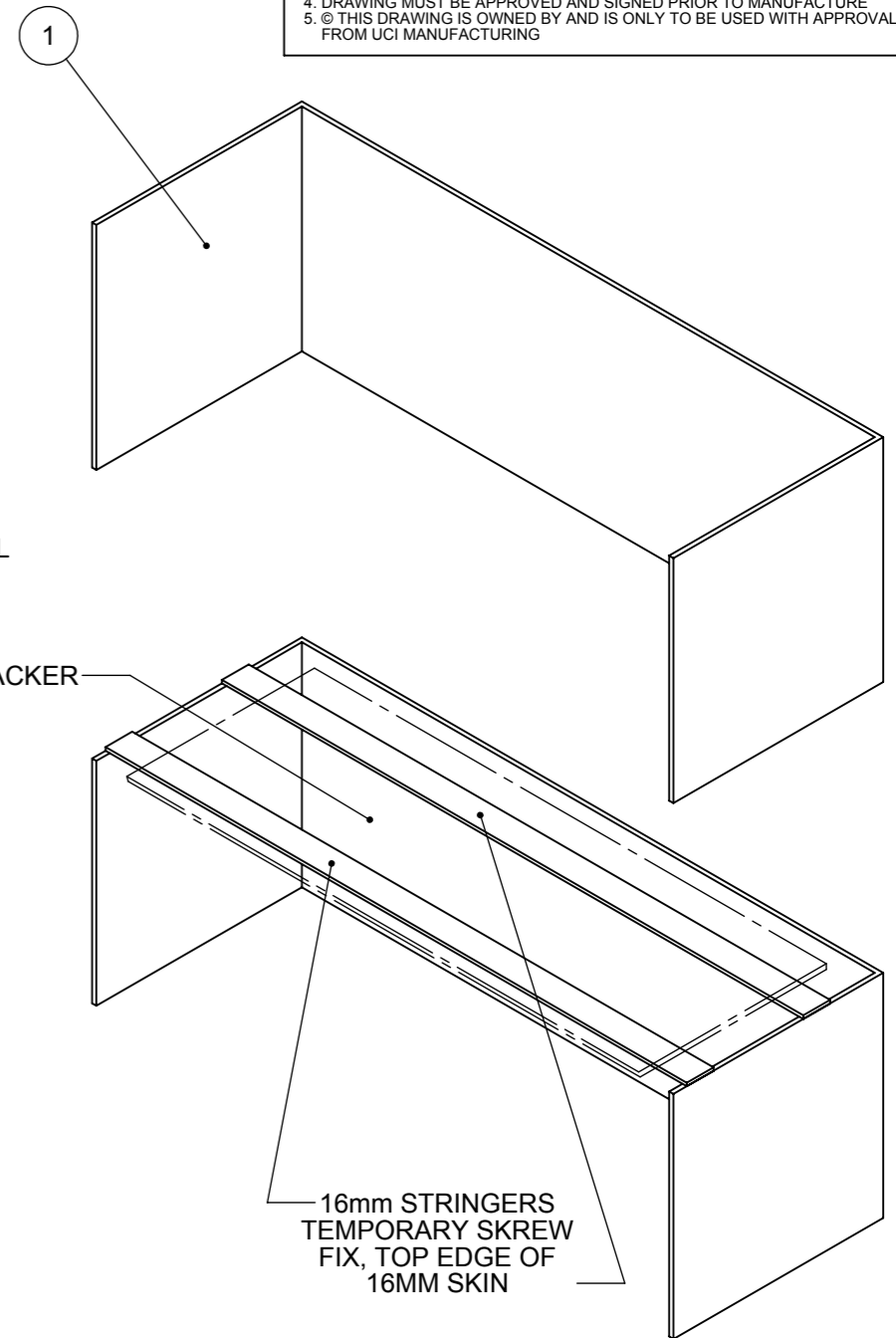
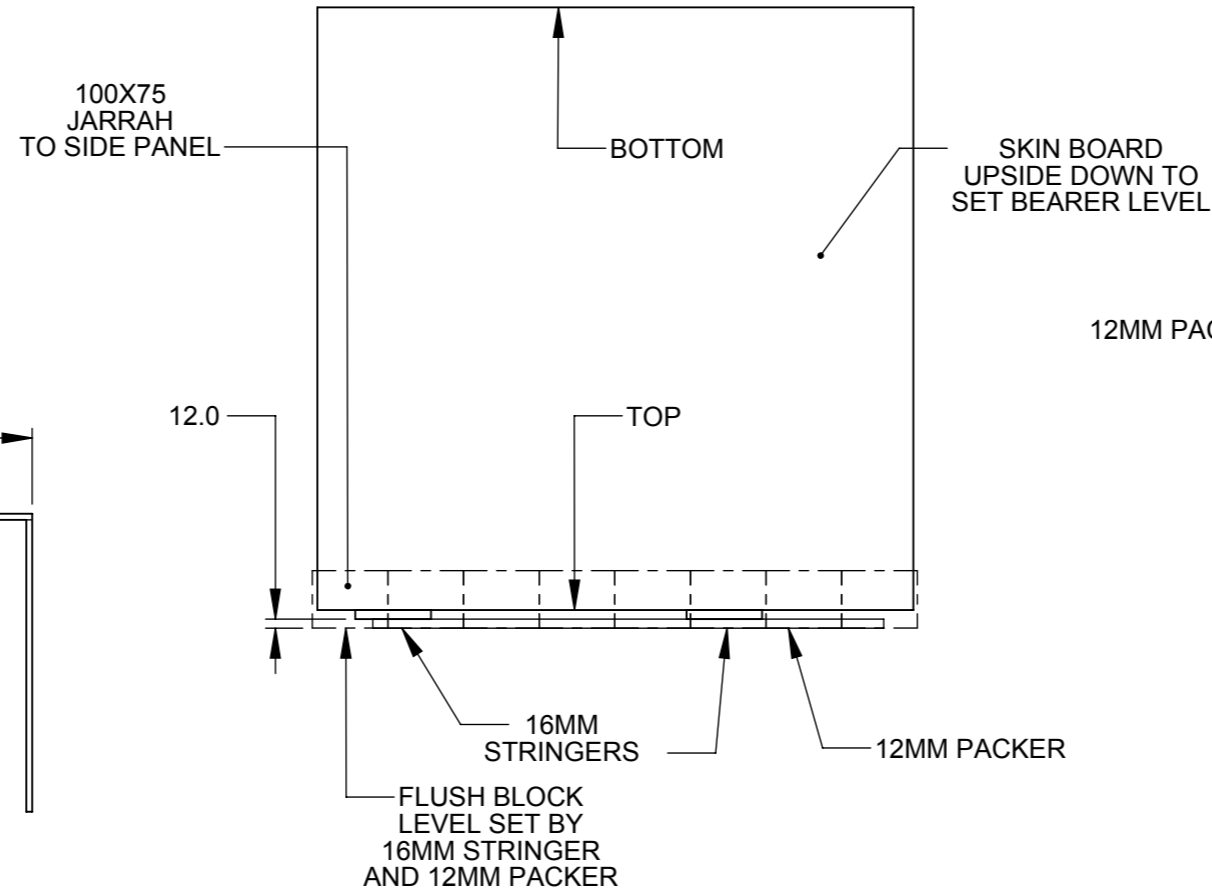

TOP VIEW



FRONT VIEW

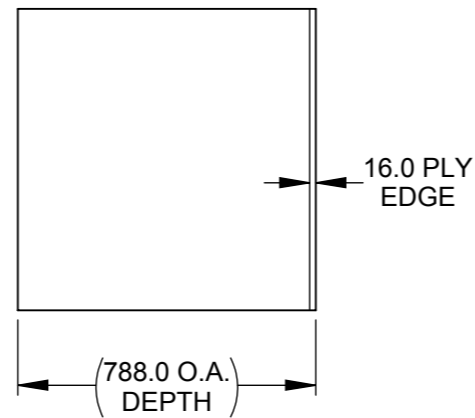

SIDE VIEW

ALL DIMENSIONS IN MILLIMETRES UNLESS OTHERWISE SPECIFIED. GENERAL TOLERANCE: 0 DECIMAL (0) ±0.5; 1 DECIMAL (0.0) ±0.2; 2 DECIMALS (0.00) ±0.1; ANGLES ±0.5

DESCRIPTION					
SEPPELTSFIELD SHOWROOM					
DRAWN BY	DRAWN DATE	CLUSTER			
AG	10.09.13	SKIN BOARD (FOR JARRAH CLADDING)			
DO NOT SCALE DRAWING	SHEET	PAGE	SCALE	CODE	Rev
	A3				

MATERIALS FINISH

CODE	ITEM	MATERIAL	FINISH
1	100X75 BLOCKS	RECLAIMED JARRAH	NATURAL / WIRE BRUSHED
2	SKIN BOARD	16mm BIRCH PLY	WHITENED EDGE + INTERNAL FACES / BLACK OUTSIDE FACE 10% CLEAR

NOTES:
 1. BALLOONED DIMENSIONS ARE CRITICAL INSPECTION DIMENSIONS
 2. DIMENSIONS IN PARENTHESIS ARE FOR REFERENCE ONLY (NON CRITICAL)
 3. ANY MODIFICATIONS FROM INITIAL APPROVED SAMPLE MUST BE SUBMITTED FOR APPROVAL
 4. DRAWING MUST BE APPROVED AND SIGNED PRIOR TO MANUFACTURE
 5. © THIS DRAWING IS OWNED BY AND IS ONLY TO BE USED WITH APPROVAL FROM UCI MANUFACTURING

JARRAH ROUTE DEPTH
 CHANGE IN DEPTH = 12mm

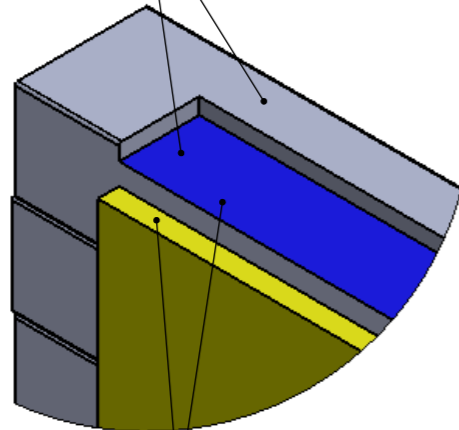

CHANGE OF DEPTH = 16mm
 FROM ROUTED SURFACE TO TOP
 OF 16mm PLY "SKIN BOARD"

DETAIL A
 SCALE 1 : 4

RHS PANEL

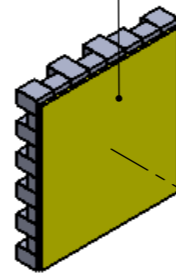

A

REAR PANEL

LHS PANEL

EXPLODED ISO: SCALE 1:30

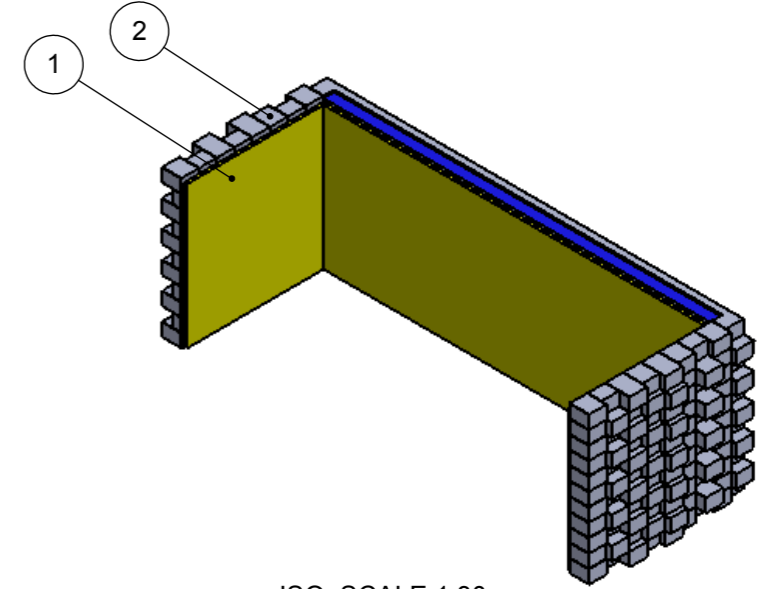

ISO: SCALE 1:30

FRONT
 OF
 CABINET

REAR
 OF
 CABINET

FRONT
 OF
 CABINET

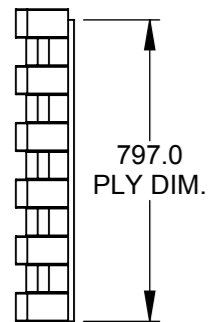
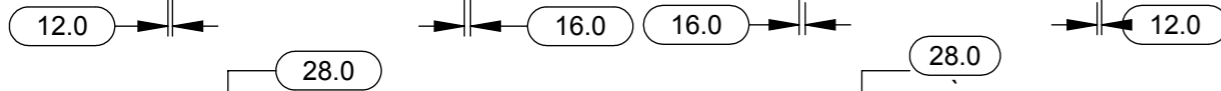

LHS PANEL

772.0
 PLY DIM.

RHS PANEL

772.0
 PLY DIM.

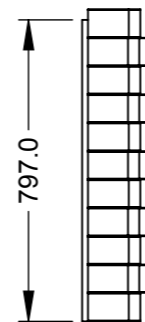

28.0

797.0
 PLY DIMENSION

REAR PANEL

2184.0
 PLY DIMENSION

ALL DIMENSIONS IN MILLIMETRES UNLESS OTHERWISE SPECIFIED. GENERAL TOLERANCE: 0 DECIMAL (0) ±0.5; 1 DECIMAL (0.0) ±0.2; 2 DECIMALS (0.00) ±0.1; ANGLES ±0.5

DESCRIPTION						
SEPPELTSFIELD SHOWROOM						
DRAWN BY AG	DRAWN DATE 10.09.13	CLUSTER 1. JARRAH CLADDING + 2. SKIN BOARD				
DO NOT SCALE DRAWING	SHEET A3	PAGE 4 OF 13	SCALE 1:20	CODE N/A	Rev 1	

MATERIALS FINISH

CODE	ITEM	MATERIAL	FINISH
-	-	-	-
3	SKIN COVER	16mm BIRCH PLY	WHITENED EDGE + INTERNAL FACES 10% CLEAR

NOTES:
 1. BALLOONED DIMENSIONS ARE CRITICAL INSPECTION DIMENSIONS
 2. DIMENSIONS IN PARENTHESIS ARE FOR REFERENCE ONLY (NON CRITICAL)
 3. ANY MODIFICATIONS FROM INITIAL APPROVED SAMPLE MUST BE SUBMITTED FOR APPROVAL
 4. DRAWING MUST BE APPROVED AND SIGNED PRIOR TO MANUFACTURE
 5. © THIS DRAWING IS OWNED BY AND IS ONLY TO BE USED WITH APPROVAL FROM UCI MANUFACTURING

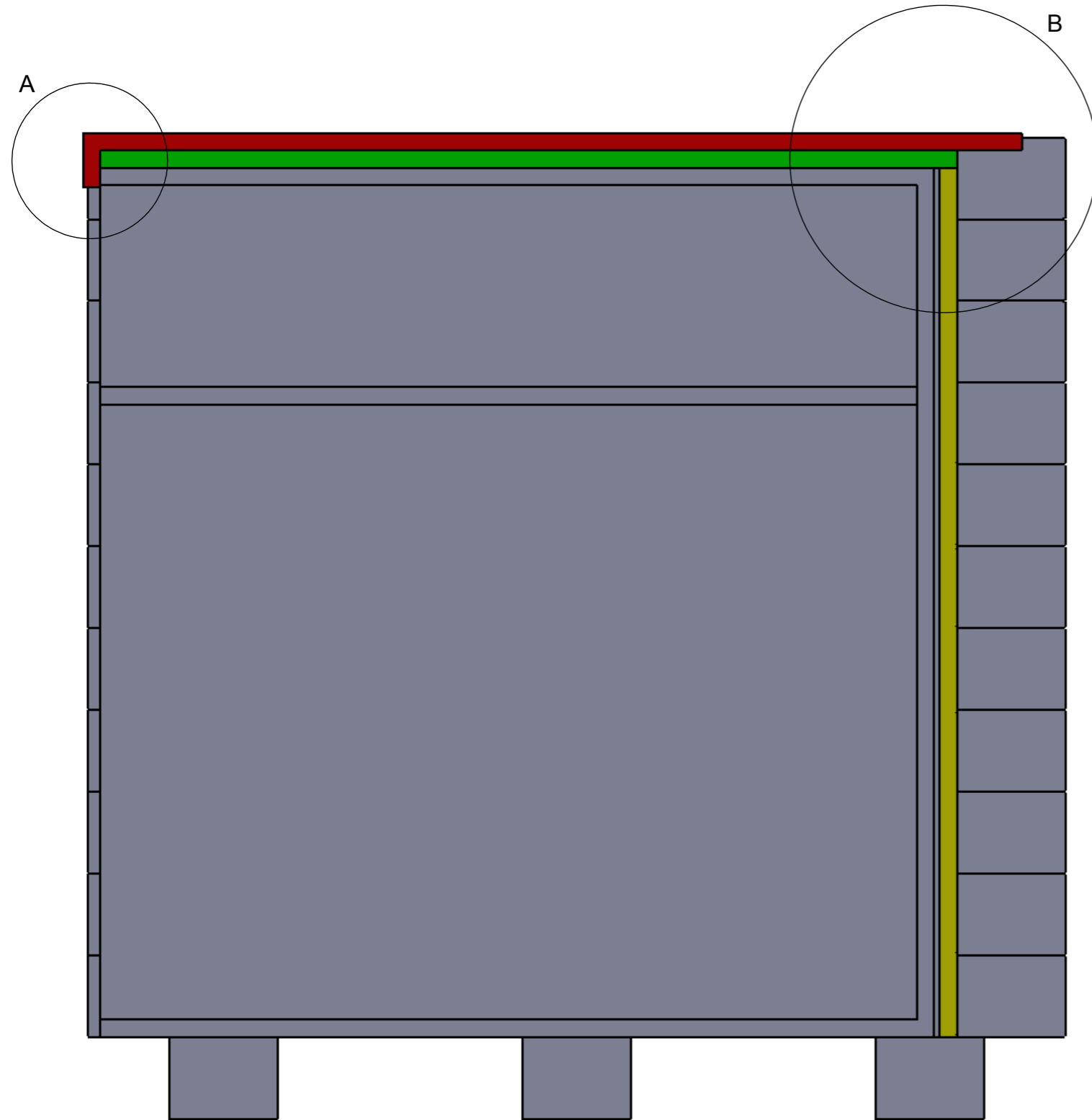

SKIN COVER SITTING OVER CABINET AND INTO ROUTED JARRAH

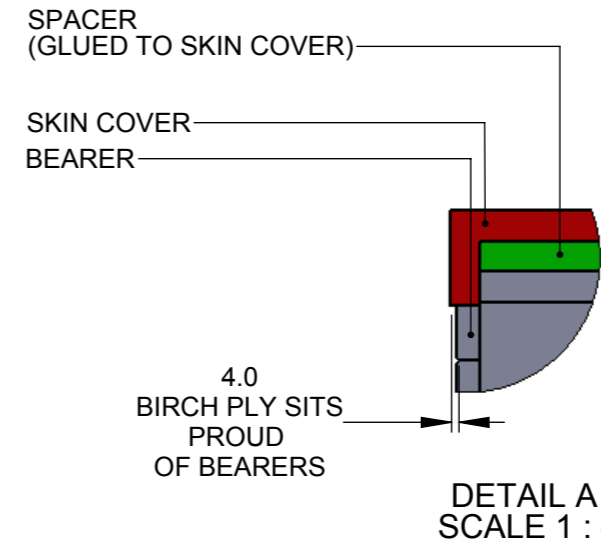

*NOTE:
 THIS DIMENSION "60" IS "FIT FOR FIT" THE REAR EDGE OF THE SPACER IS INTENDED TO END FLUSH WITH THE OUTSIDE FACE OF THE SKIN BOARD WHEN ASSEMBLED

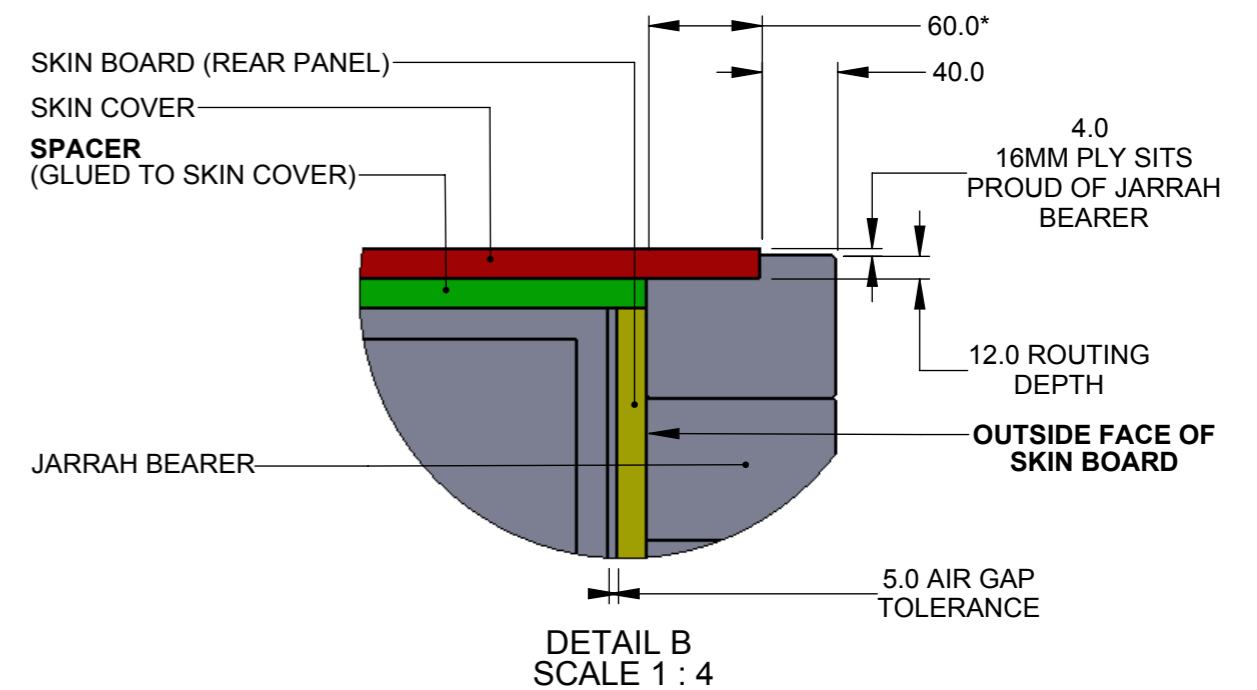

ALL DIMENSIONS IN MILLIMETRES UNLESS OTHERWISE SPECIFIED. GENERAL TOLERANCE: 0 DECIMAL (0) ±0.5; 1 DECIMAL (0.0) ±0.2; 2 DECIMALS (0.00) ±0.1; ANGLES ±0.5

DESCRIPTION						
SEPPELTSFIELD SHOWROOM						
DRAWN BY	DRAWN DATE	CLUSTER				
AG	10.09.13	SKIN COVER + SECTION VIEW OF CABINET				
DO NOT SCALE DRAWING		SHEET	PAGE	SCALE	CODE	Rev
		A3	5 OF 13	1:20	N/A	1

MATERIALS FINISH

CODE	ITEM	MATERIAL	FINISH
-	-	-	-
3	SKIN COVER	16mm BIRCH PLY	WHITENED 10% CLEAR
3A	SPACER	16mm BIRCH PLY	WHITENED 10% CLEAR

NOTES:
 1. BALLOONED DIMENSIONS ARE CRITICAL INSPECTION DIMENSIONS
 2. DIMENSIONS IN PARENTHESIS ARE FOR REFERENCE ONLY (NON CRITICAL)
 3. ANY MODIFICATIONS FROM INITIAL APPROVED SAMPLE MUST BE SUBMITTED FOR APPROVAL
 4. DRAWING MUST BE APPROVED AND SIGNED PRIOR TO MANUFACTURE
 5. © THIS DRAWING IS OWNED BY AND IS ONLY TO BE USED WITH APPROVAL FROM UCI MANUFACTURING

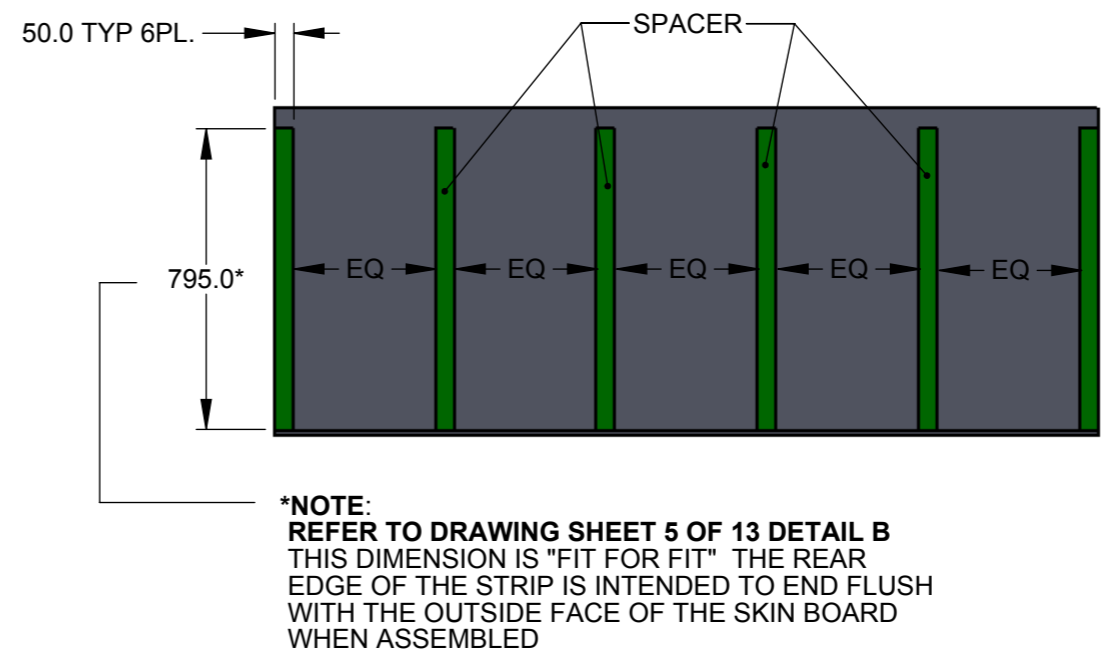
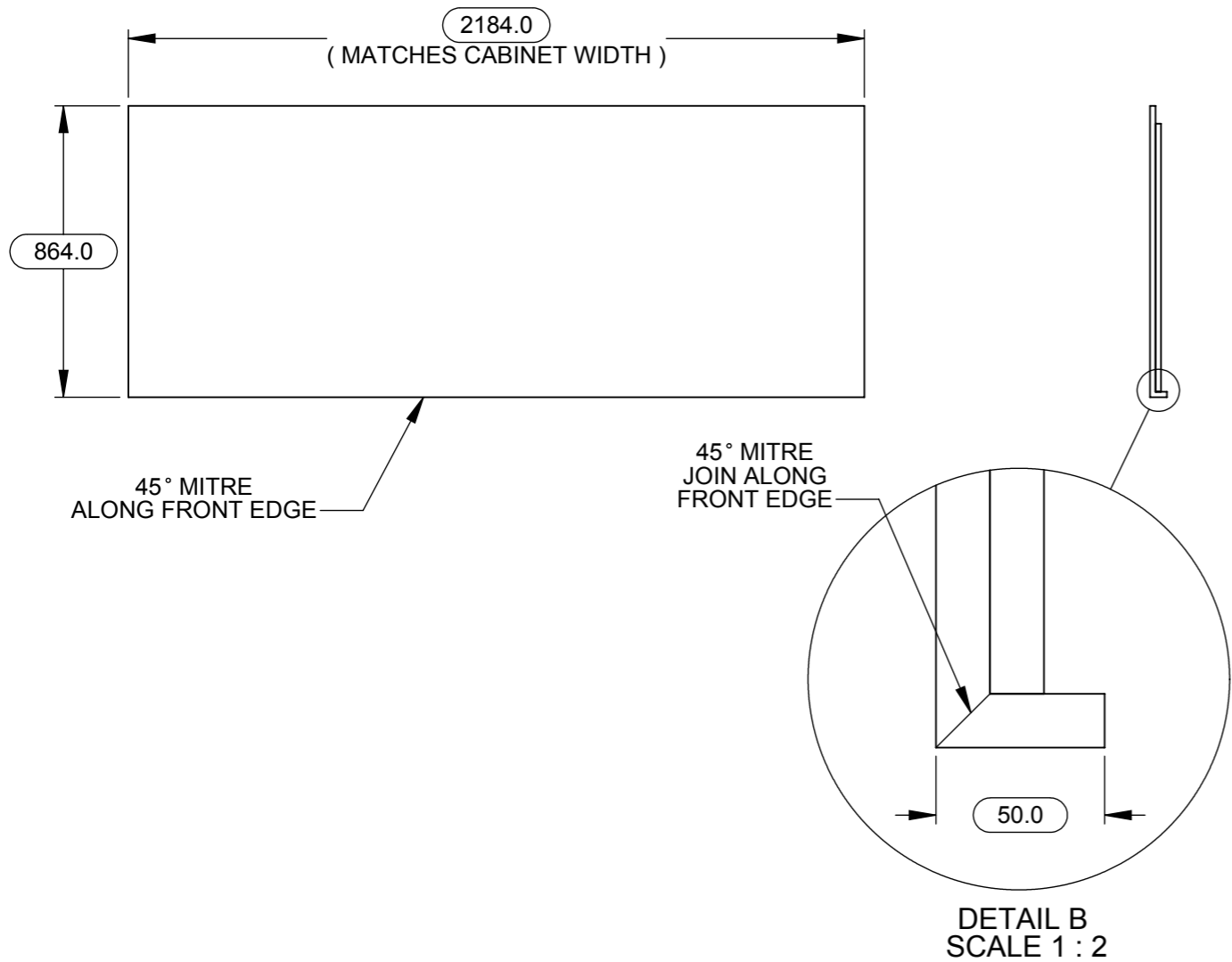
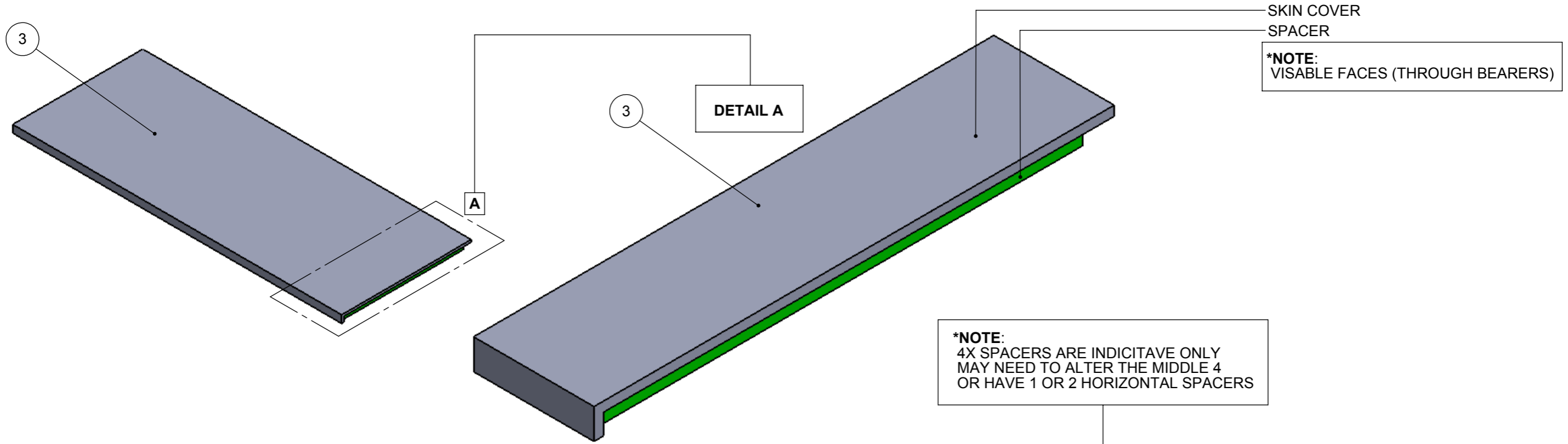

ALL DIMENSIONS IN MILLIMETRES UNLESS OTHERWISE SPECIFIED. GENERAL TOLERANCE: 0 DECIMAL (0) ±0.5; 1 DECIMAL (0.0) ±0.2; 2 DECIMALS (0.00) ±0.1; ANGLES ±0.5

DESCRIPTION					
SEPPELTSFIELD SHOWROOM					
DRAWN BY	DRAWN DATE	CLUSTER			
AG	10.09.13	SKIN COVER + SECTION VIEW OF CABINET			
DO NOT SCALE DRAWING		SHEET	PAGE	SCALE	CODE
		A3	6 OF 13	1:20	N/A
					Rev
					1

MATERIALS FINISH

CODE	ITEM	MATERIAL	FINISH
1	100X75 BLOCKS	RECLAIMED JARRAH	NATURAL / WIRE BRUSHED
2	SKIN BOARD	16MM BIRCH PLY	WHITENED, 10% CLEAR

NOTES:
 1. BALLOONED DIMENSIONS ARE CRITICAL INSPECTION DIMENSIONS
 2. DIMENSIONS IN PARENTHESIS ARE FOR REFERENCE ONLY (NON CRITICAL)
 3. ANY MODIFICATIONS FROM INITIAL APPROVED SAMPLE MUST BE SUBMITTED FOR APPROVAL
 4. DRAWING MUST BE APPROVED AND SIGNED PRIOR TO MANUFACTURE
 5. © THIS DRAWING IS OWNED BY AND IS ONLY TO BE USED WITH APPROVAL FROM UCI MANUFACTURING

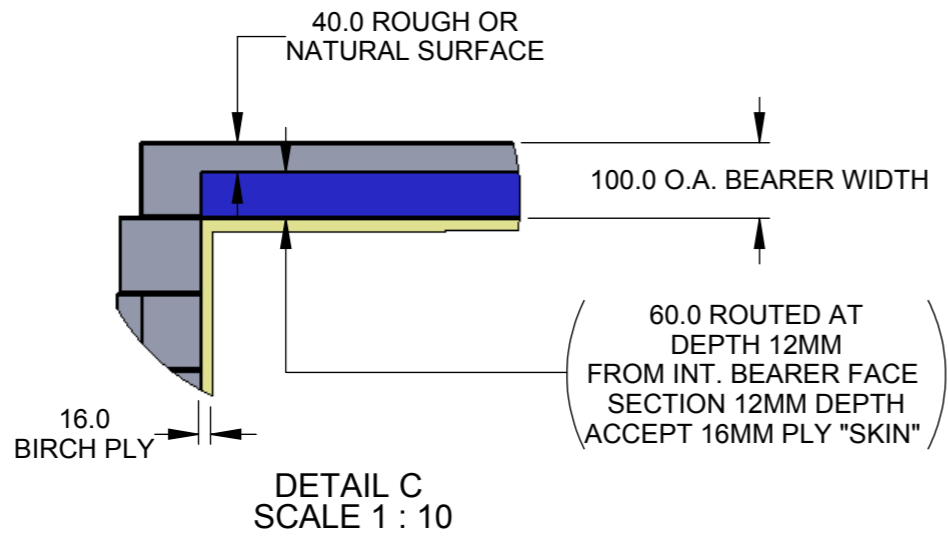

10 - 20mm (SMALL UNDULATION) BLOCK VARIATION

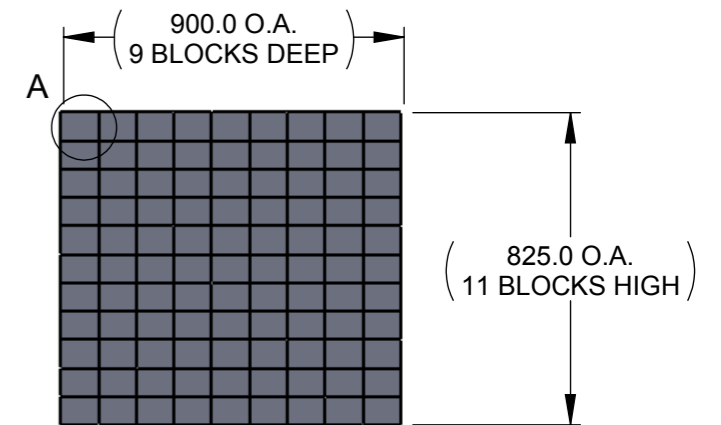
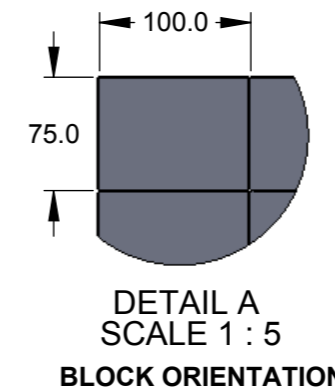
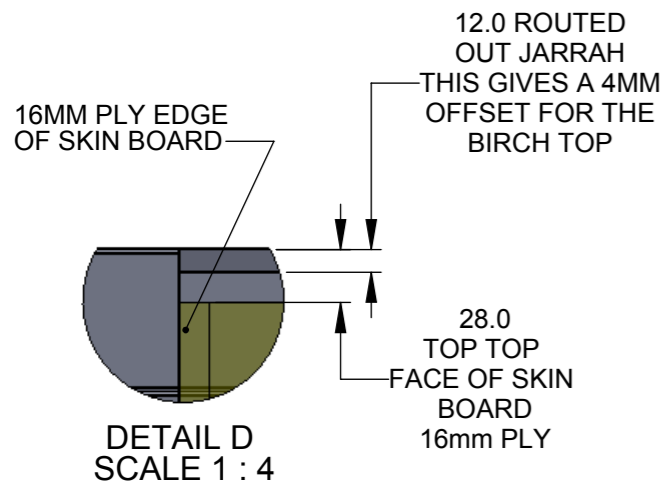
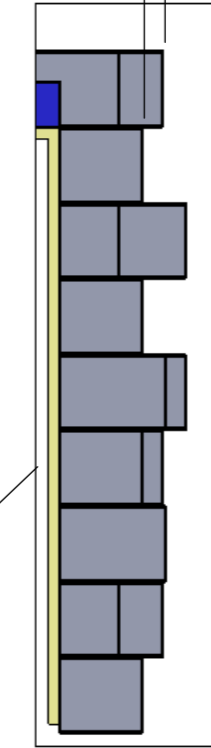
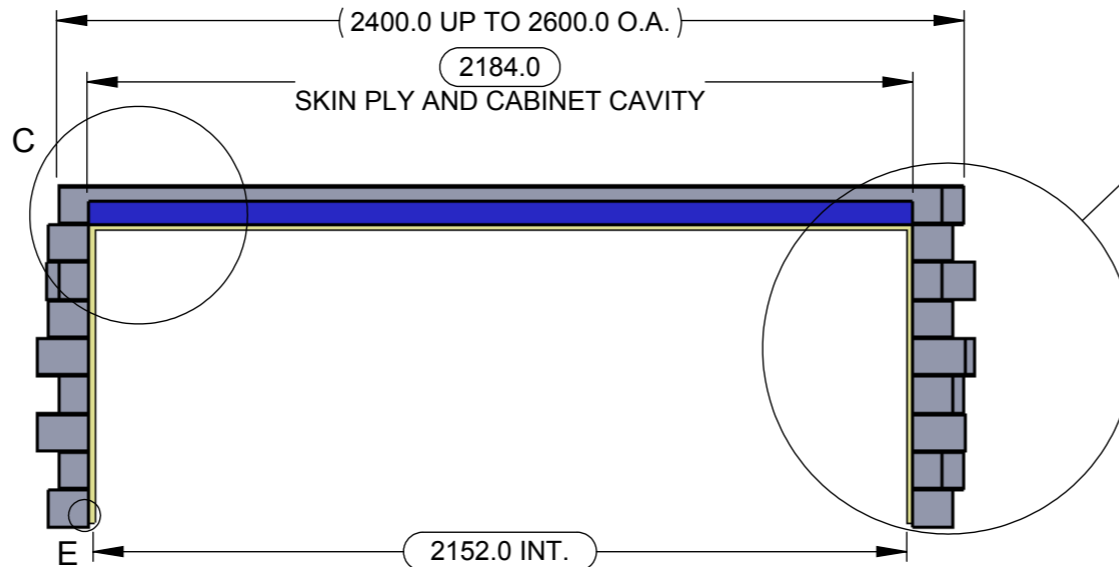
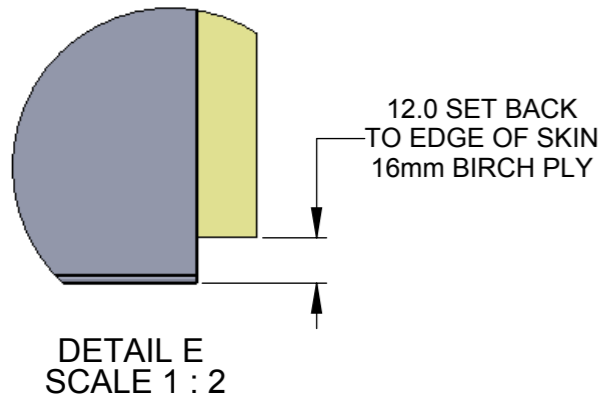
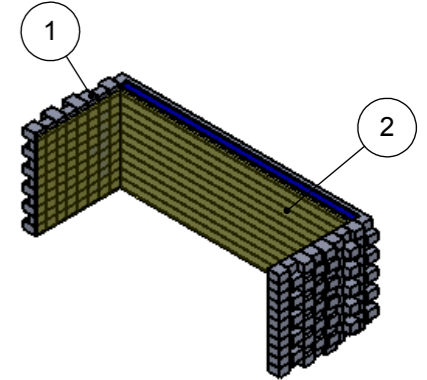

ALL DIMENSIONS IN MILLIMETRES UNLESS OTHERWISE SPECIFIED. GENERAL TOLERANCE: 0 DECIMAL (0) ±0.5; 1 DECIMAL (0.0) ±0.2; 2 DECIMALS (0.00) ±0.1; ANGLES ±0.5

DESCRIPTION						
SEPPELTSFIELD SHOWROOM						
DRAWN BY AG	DRAWN DATE 10.09.13	CLUSTER 1. JARRAH CLADDING 2. SKIN REFERANCE DIMENSIONS				
DO NOT SCALE DRAWING		SHEET A3	PAGE 7 OF 13	SCALE 1:20	CODE N/A	Rev 1

MATERIALS FINISH

CODE	ITEM	MATERIAL	FINISH
2	SKIN BOARD	16MM BIRCH PLY	WHITENED, 10% CLEAR
4	CABINET	16mm BIRCH PLY	WHITENED, 10% CLEAR

NOTES:
 1. BALLOONED DIMENSIONS ARE CRITICAL INSPECTION DIMENSIONS
 2. DIMENSIONS IN PARENTHESIS ARE FOR REFERENCE ONLY (NON CRITICAL)
 3. ANY MODIFICATIONS FROM INITIAL APPROVED SAMPLE MUST BE SUBMITTED FOR APPROVAL
 4. DRAWING MUST BE APPROVED AND SIGNED PRIOR TO MANUFACTURE
 5. © THIS DRAWING IS OWNED BY AND IS ONLY TO BE USED WITH APPROVAL FROM UCI MANUFACTURING

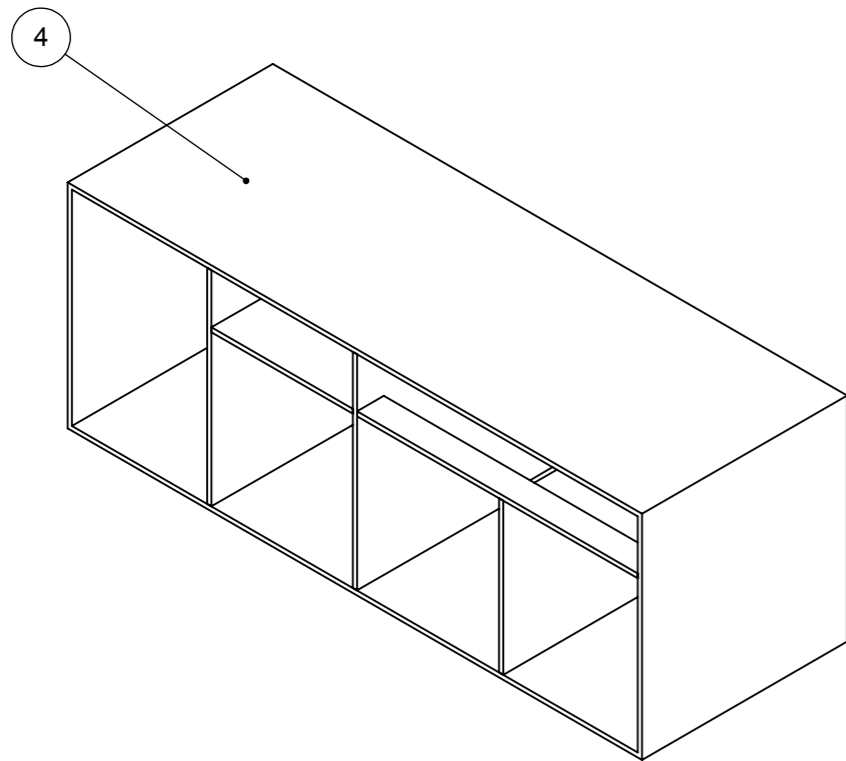

CABINET ONLY

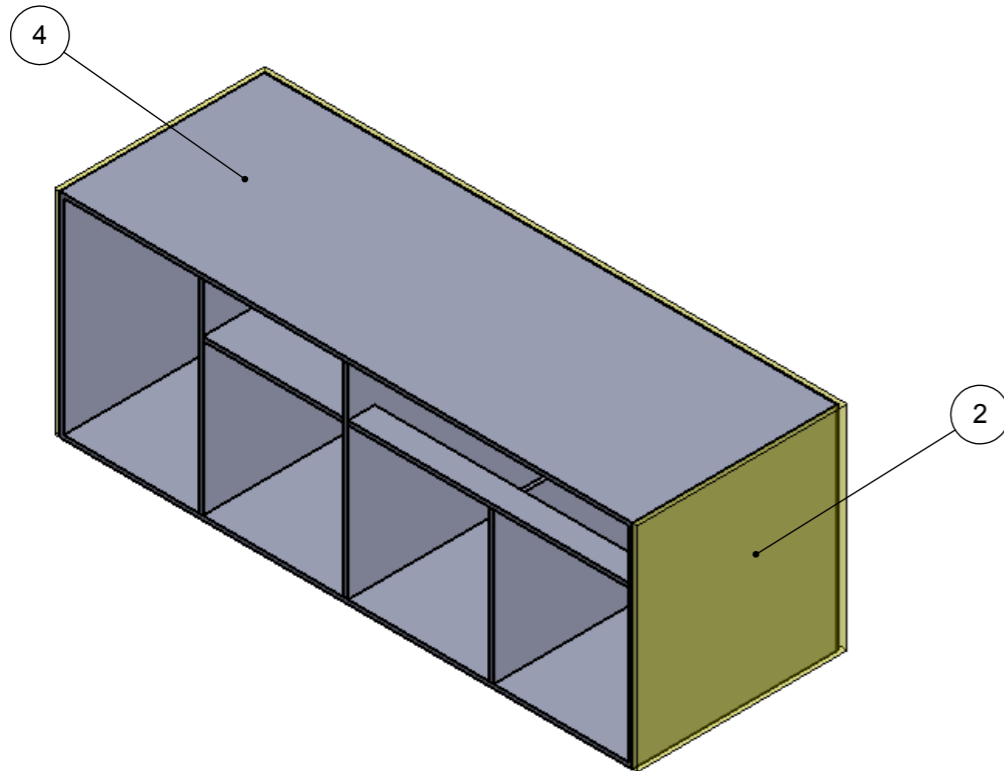
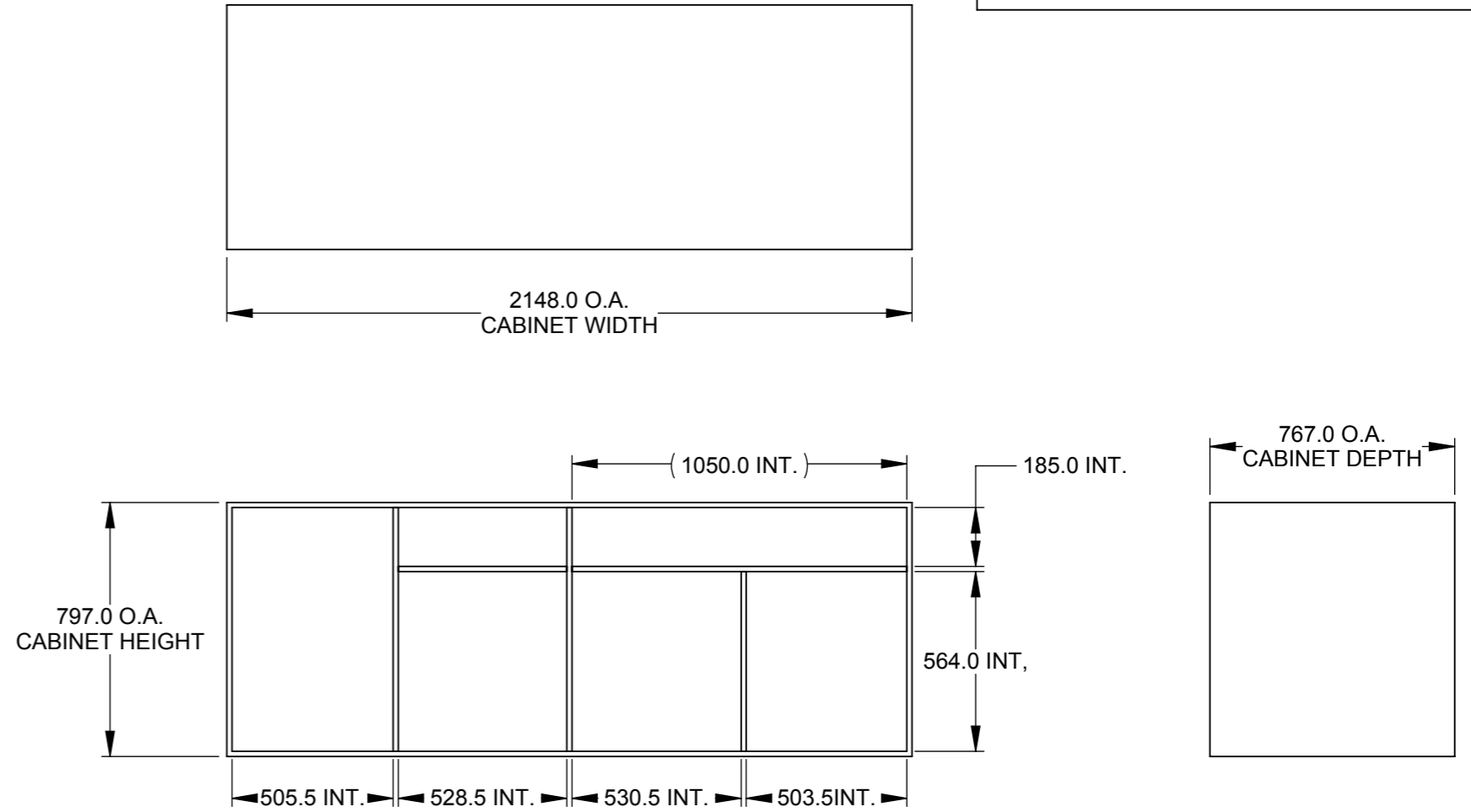

CABINET WITH SKIN (NO JARRAH SHOWN)

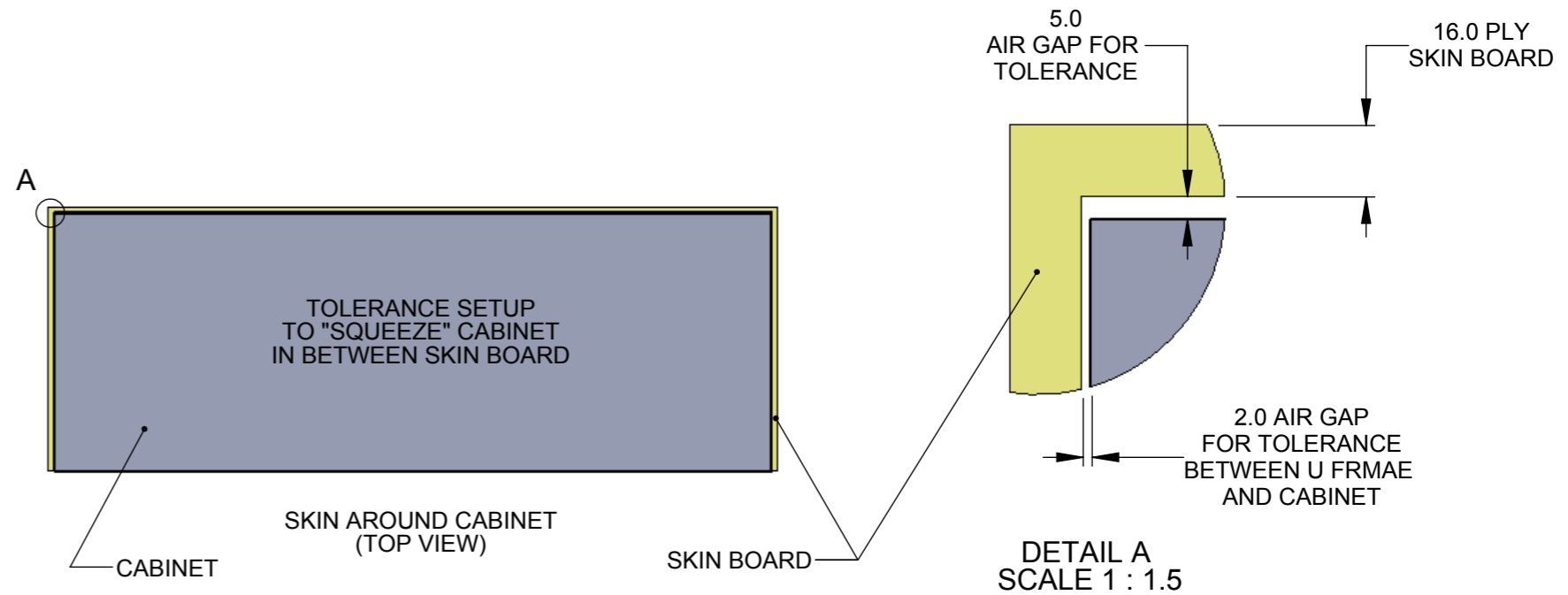

ALL DIMENSIONS IN MILLIMETRES UNLESS OTHERWISE SPECIFIED. GENERAL TOLERANCE: 0 DECIMAL (0) ±0.5; 1 DECIMAL (0.0) ±0.2; 2 DECIMALS (0.00) ±0.1; ANGLES ±0.5

DESCRIPTION						
SEPPELTSFIELD SHOWROOM						
DRAWN BY	DRAWN DATE	CLUSTER				
AG	10.09.13	CABINET				
DO NOT SCALE DRAWING	SHEET		PAGE	SCALE	CODE	Rev
	A3		8 OF 13	1:20	N/A	1

MATERIALS FINISH

CODE	ITEM	MATERIAL	FINISH
-	-	-	-
4	CABINET	16mm BIRCH PLY	WHITENED, 10% CLEAR

GLUE AND SKREW CONSTRUCTION

NOTES:
 1. BALLOONED DIMENSIONS ARE CRITICAL INSPECTION DIMENSIONS
 2. DIMENSIONS IN PARENTHESIS ARE FOR REFERENCE ONLY (NON CRITICAL)
 3. ANY MODIFICATIONS FROM INITIAL APPROVED SAMPLE MUST BE SUBMITTED FOR APPROVAL
 4. DRAWING MUST BE APPROVED AND SIGNED PRIOR TO MANUFACTURE
 5. © THIS DRAWING IS OWNED BY AND IS ONLY TO BE USED WITH APPROVAL FROM UCI MANUFACTURING

1

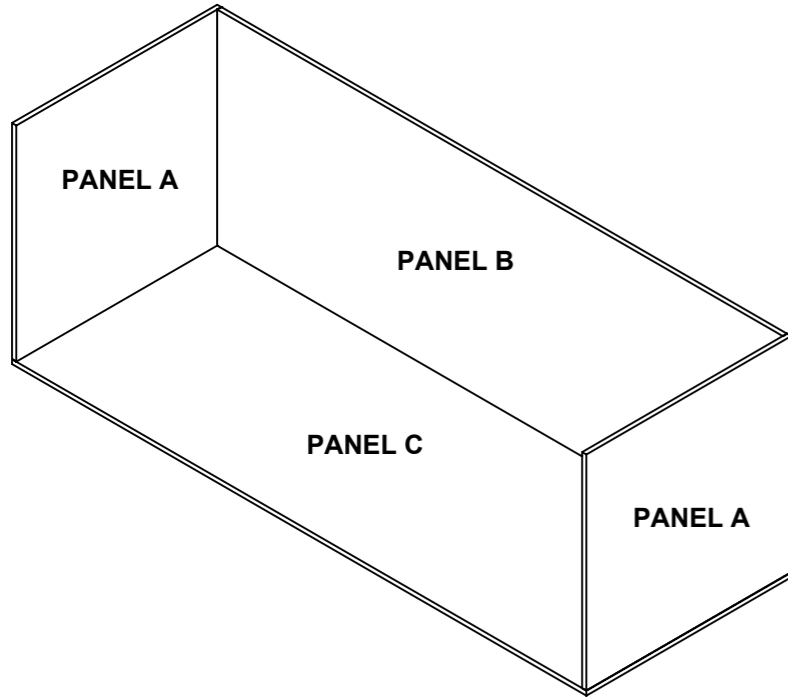

2

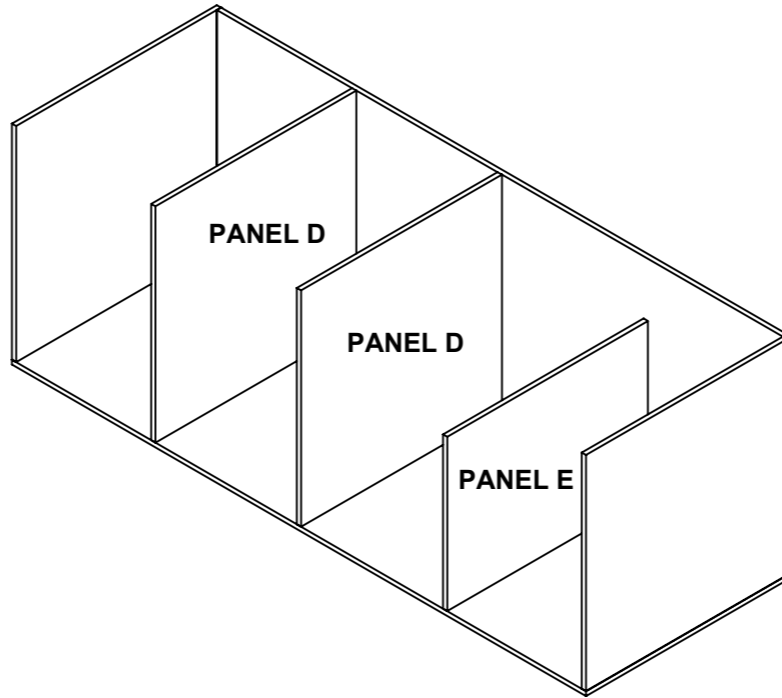

3

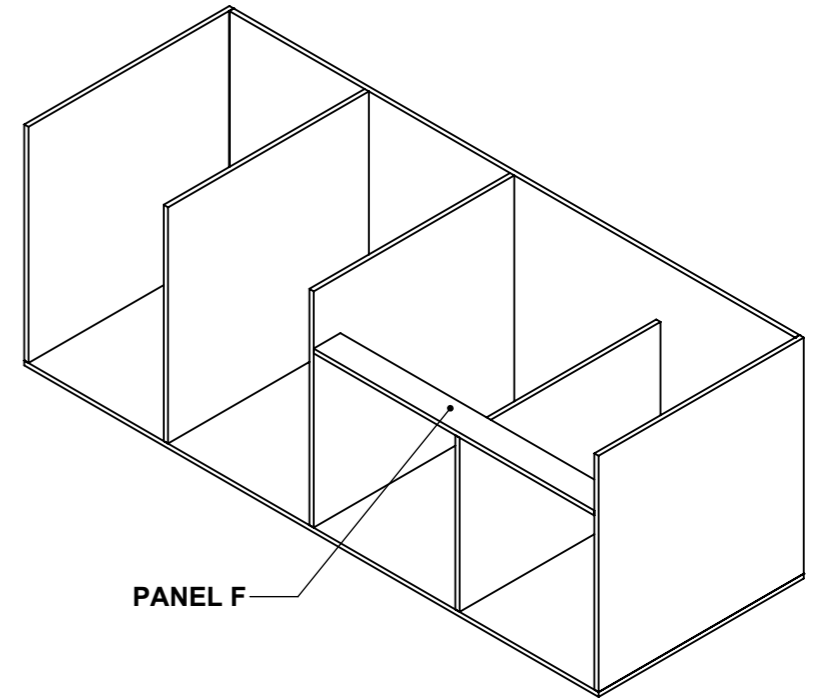

4

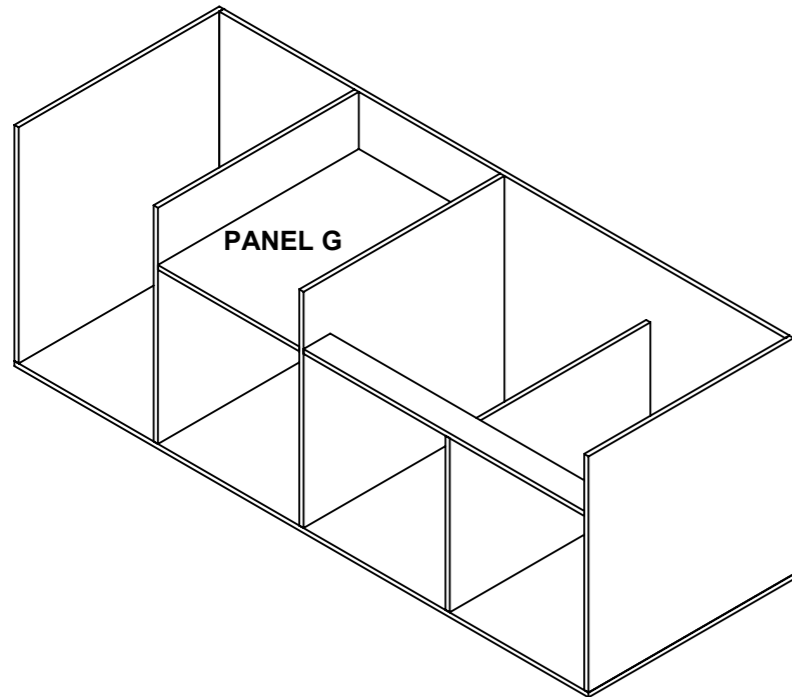

5

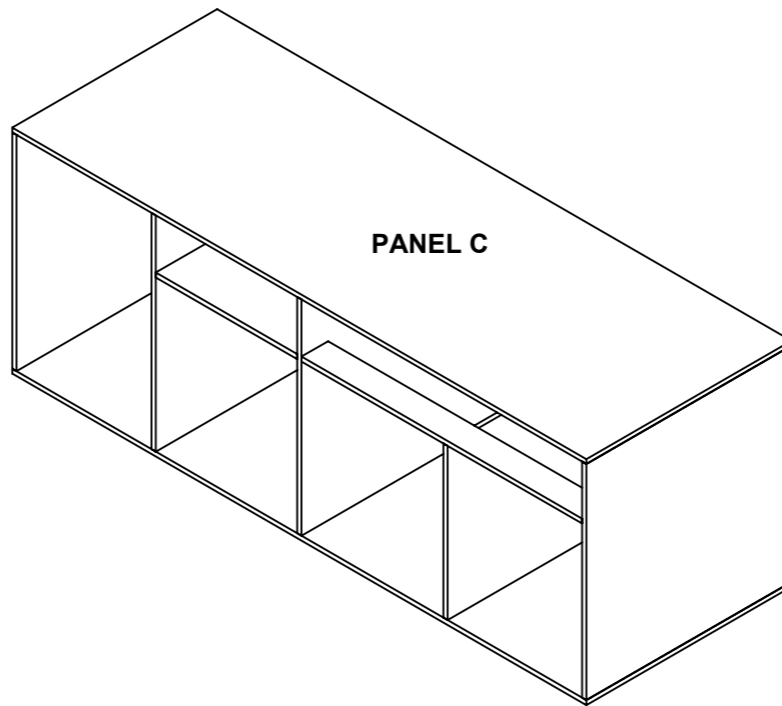

CUTTING LIST

NOTE: NO TOLERANCE IN DIMS.

PANEL	SIZE	QTY
A	767L X 765H	X2
B	2116L X 765H	X1
C	2148L X 767H	X2
D	751D X 765H	X2
E	751D X 564H	X1
F	1050L X 100D	X1
G	751D X 528W	X1

ALL DIMENSIONS IN MILLIMETRES UNLESS OTHERWISE SPECIFIED. GENERAL TOLERANCE: 0 DECIMAL (0) ±0.5; 1 DECIMAL (0.0) ±0.2; 2 DECIMALS (0.00) ±0.1; ANGLES ±0.5

DESCRIPTION						SEPPELTSFIELD SHOWROOM		
DRAWN BY	DRAWN DATE	CLUSTER						
AG	10.09.13	CABINET SEQUENTIAL CONSTRUCTION						
DO NOT SCALE DRAWING		SHEET	PAGE	SCALE	CODE	Rev		
		A3	8A OF 13	1:20	N/A	1		

MATERIALS FINISH

CODE	ITEM	MATERIAL	FINISH
-	-	-	-
6A	WRAPPING DRAWER DRAWER FRONT	16mm BIRCH PLY	WHITENED 10% CLEAR
6B	WRAPPING DRAWER	12mm BIRCH PLY	WHITENED 10% CLEAR
6C	WRAPPING DRAWER DRAWER BOTTOM	9MM BIRCH PLY	WHITENED 10% CLEAR
6D	WRAPPING DRAWER PAPER RISER	9MM BIRCH PLY	WHITENED 10% CLEAR
6E	WRAPPING DRAWER PAER RISER TRAY	9MM BIRCH PLY	WHITENED 10% CLEAR

NOTE:
DRAWER O.A. DIM. HAS BEEN DETERMINED WITH THE ASSUPTION THAT A STANDARD DRAWER RUNNER WILL BE USED. THEREFORE A 12.5MM OFFSET FROM THE EXT. WALL OF THE DRAWER TO INT. WALL OF THE DIVIDER/CABINET HAS BEEN USED

NOTES:
1. BALLOONED DIMENSIONS ARE CRITICAL INSPECTION DIMENSIONS
2. DIMENSIONS IN PARENTHESIS ARE FOR REFERENCE ONLY (NON CRITICAL)
3. ANY MODIFICATIONS FROM INITIAL APPROVED SAMPLE MUST BE SUBMITTED FOR APPROVAL
4. DRAWING MUST BE APPROVED AND SIGNED PRIOR TO MANUFACTURE
5. © THIS DRAWING IS OWNED BY AND IS ONLY TO BE USED WITH APPROVAL FROM UCI MANUFACTURING



SECTION AA-AA
SCALE 1 : 10

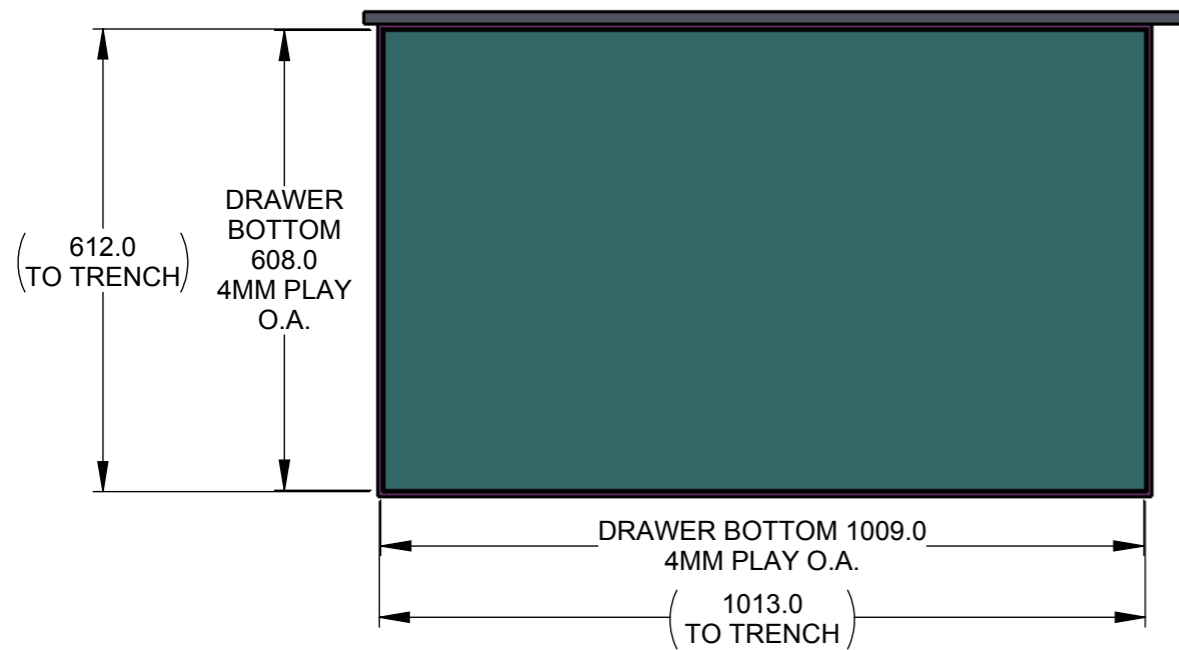
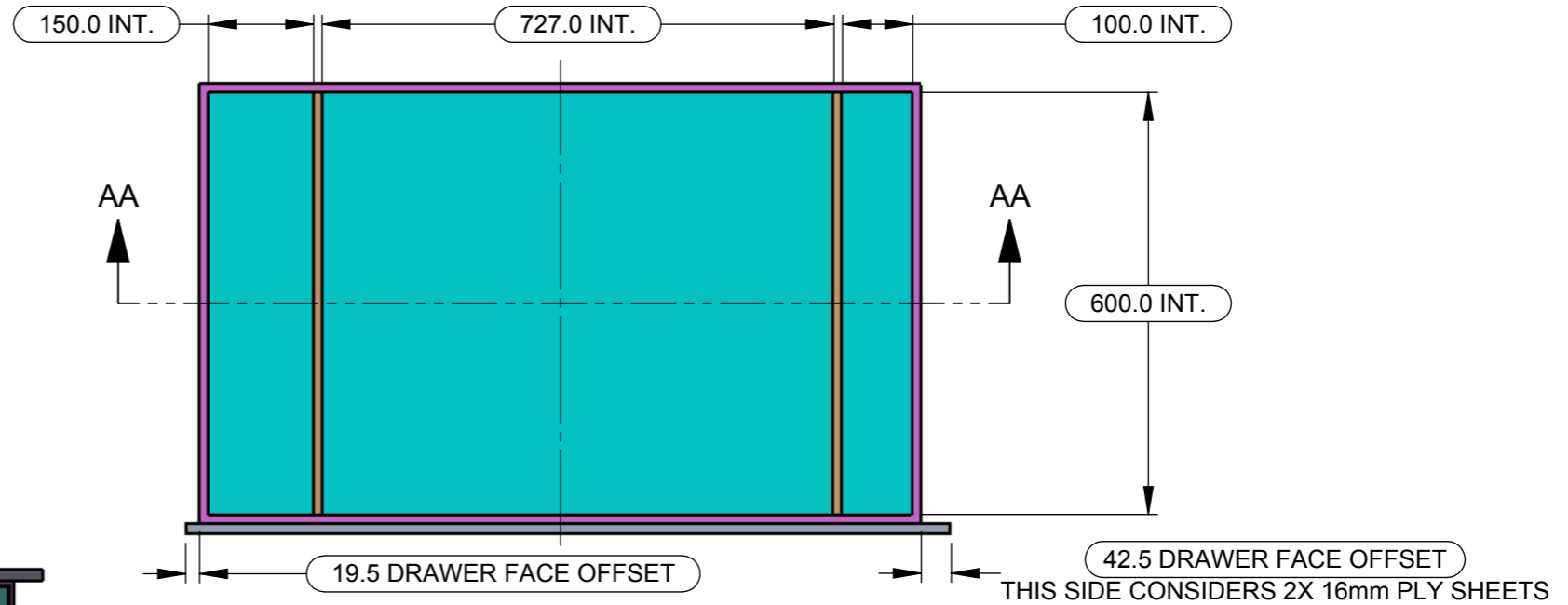
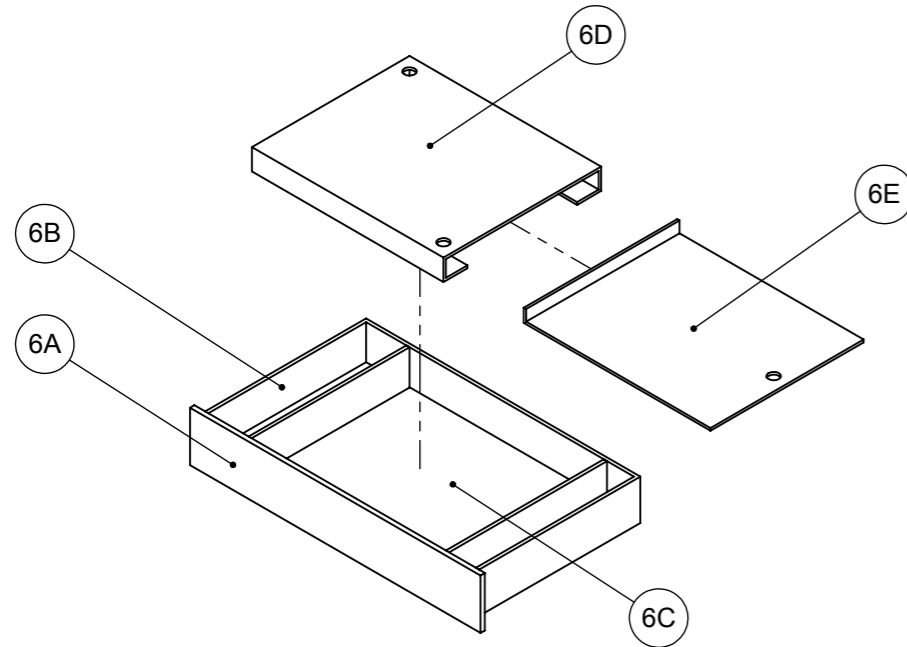
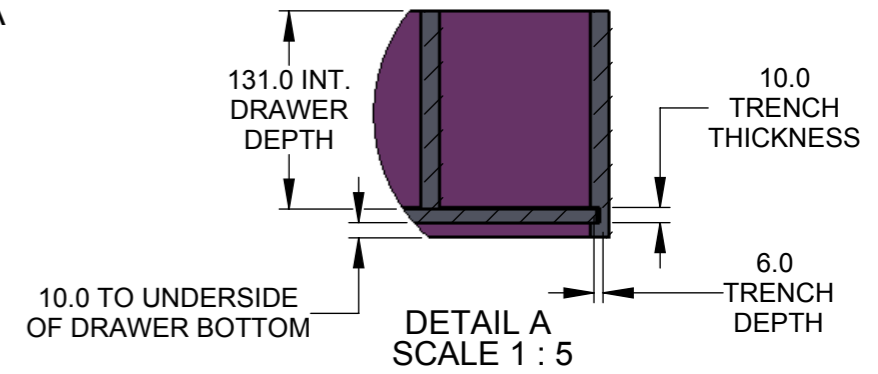

SECTION BB-BB
SCALE 1 : 10

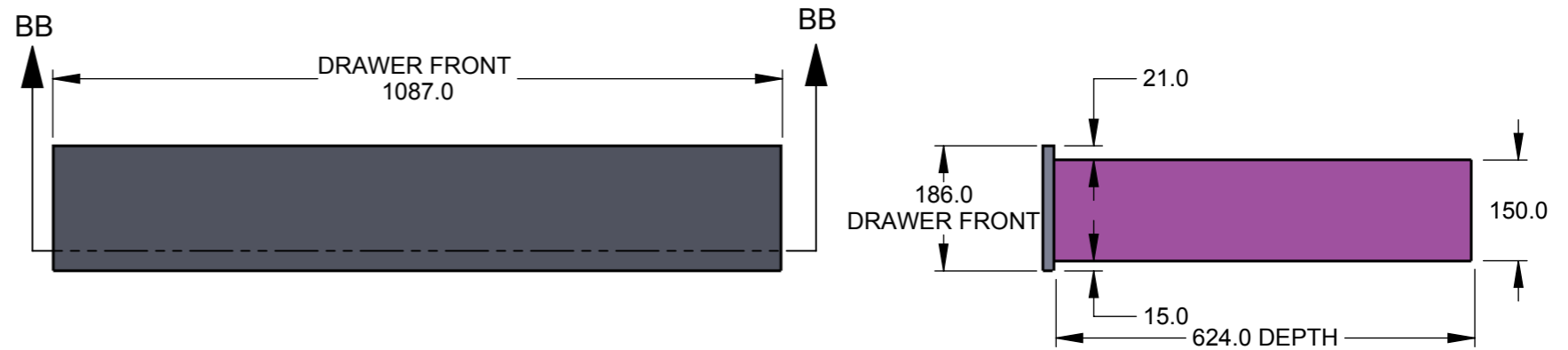

ALL DIMENSIONS IN MILLIMETRES UNLESS OTHERWISE SPECIFIED. GENERAL TOLERANCE: 0 DECIMAL (0) ±0.5; 1 DECIMAL (0.0) ±0.2; 2 DECIMALS (0.00) ±0.1; ANGLES ±0.5

DESCRIPTION SEPPELTSFIELD SHOWROOM									
DRAWN BY AG	DRAWN DATE 10.09.13	CLUSTER WRAPPING DRAWER							
DO NOT SCALE DRAWING		SHEET A3		PAGE 9 OF 13	SCALE 1:20	CODE N/A	Rev 1		

MATERIALS FINISH

CODE	ITEM	MATERIAL	FINISH
-	-	-	-
6A	WRAPPING DRAWER DRAWER FRONT	16mm BIRCH PLY	WHITENED 10% CLEAR
6B	WRAPPING DRAWER	12mm BIRCH PLY	WHITENED 10% CLEAR
6C	WRAPPING DRAWER DRAWER BOTTOM	9MM BIRCH PLY	WHITENED 10% CLEAR
6D	WRAPPING DRAWER PAPER RISER	9MM BIRCH PLY	WHITENED 10% CLEAR
6E	WRAPPING DRAWER PAER RISER TRAY	9MM BIRCH PLY	WHITENED 10% CLEAR

NOTES:
 1. BALLOONED DIMENSIONS ARE CRITICAL INSPECTION DIMENSIONS
 2. DIMENSIONS IN PARENTHESIS ARE FOR REFERENCE ONLY (NON CRITICAL)
 3. ANY MODIFICATIONS FROM INITIAL APPROVED SAMPLE MUST BE SUBMITTED FOR APPROVAL
 4. DRAWING MUST BE APPROVED AND SIGNED PRIOR TO MANUFACTURE
 5. © THIS DRAWING IS OWNED BY AND IS ONLY TO BE USED WITH APPROVAL FROM UCI MANUFACTURING

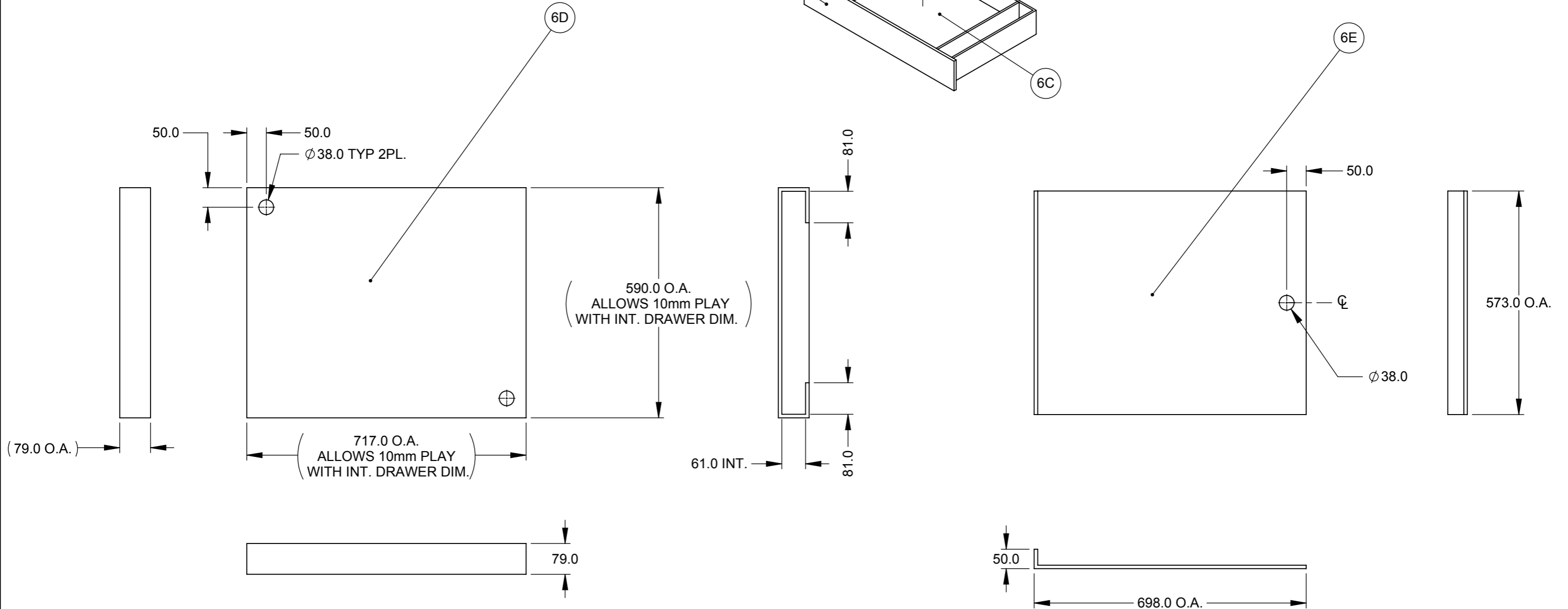
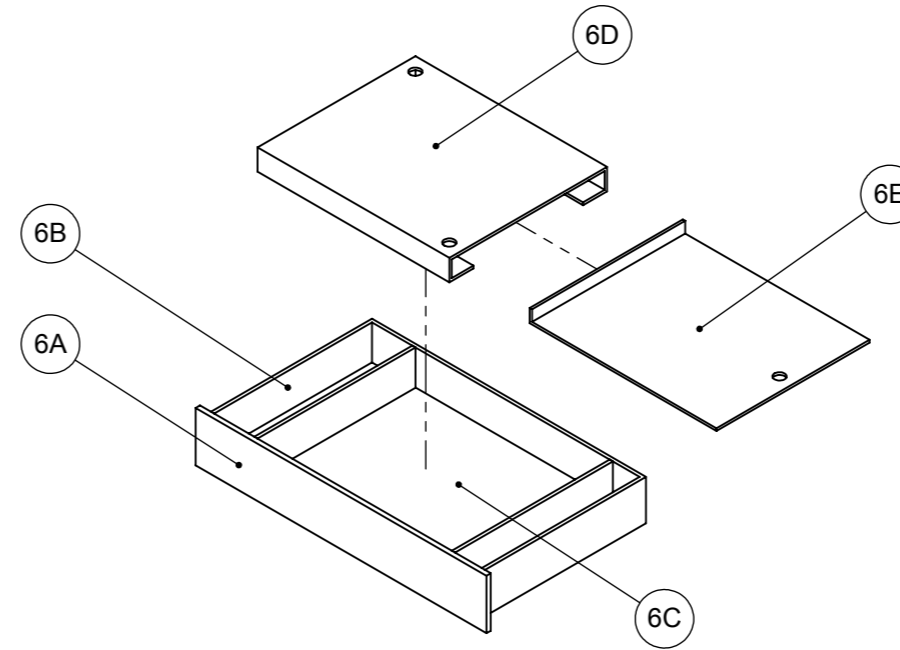

ALL DIMENSIONS IN MILLIMETRES UNLESS OTHERWISE SPECIFIED. GENERAL TOLERANCE: 0 DECIMAL (0) ±0.5; 1 DECIMAL (0.0) ±0.2; 2 DECIMALS (0.00) ±0.1; ANGLES ±0.5

DESCRIPTION					
SEPPELTSFIELD SHOWROOM					
DRAWN BY	DRAWN DATE	CLUSTER			
AG	10.09.13	WRAPPING DRAWER PAPER RISER & TRAY			
DO NOT SCALE DRAWING	SHEET	PAGE	SCALE	CODE	Rev
	A3	10 OF 13	1:20	N/A	1

MATERIALS FINISH

CODE	ITEM	MATERIAL	FINISH
-	-	-	-
3	CABINET DOORS	16mm BIRCH PLY	WHITENED 10% CLEAR

NOTES:
 1. BALLOONED DIMENSIONS ARE CRITICAL INSPECTION DIMENSIONS
 2. DIMENSIONS IN PARENTHESIS ARE FOR REFERENCE ONLY (NON CRITICAL)
 3. ANY MODIFICATIONS FROM INITIAL APPROVED SAMPLE MUST BE SUBMITTED FOR APPROVAL
 4. DRAWING MUST BE APPROVED AND SIGNED PRIOR TO MANUFACTURE
 5. © THIS DRAWING IS OWNED BY AND IS ONLY TO BE USED WITH APPROVAL FROM UCI MANUFACTURING

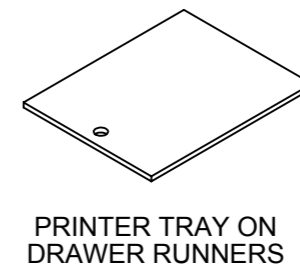
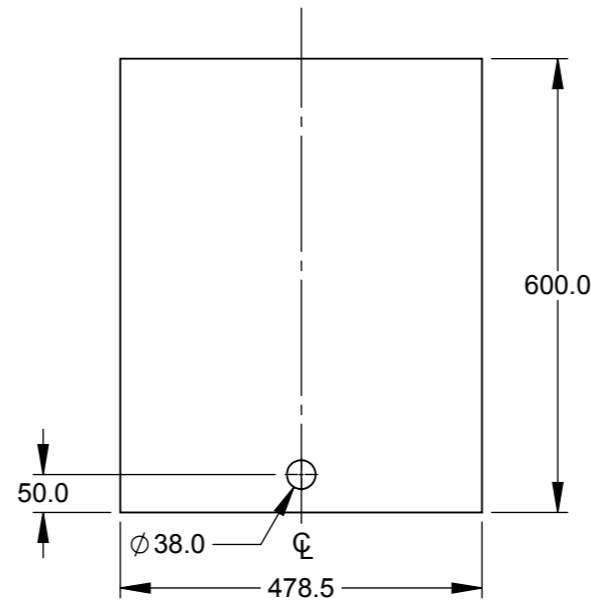
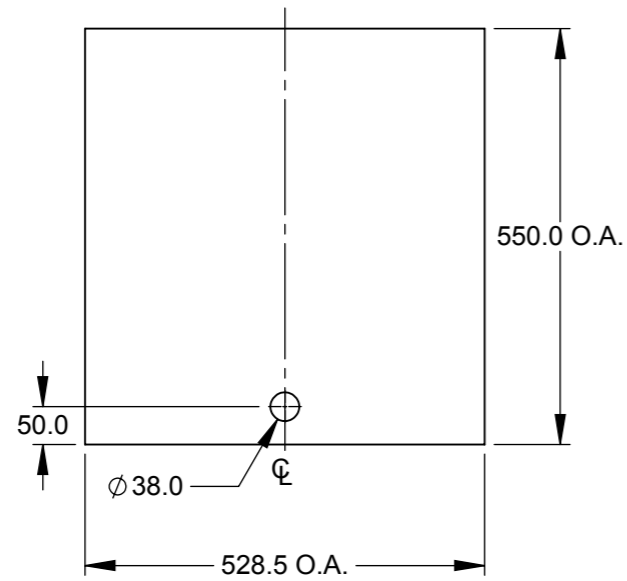
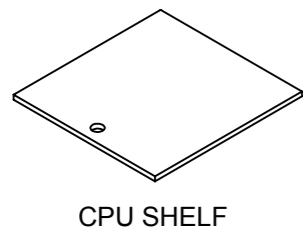
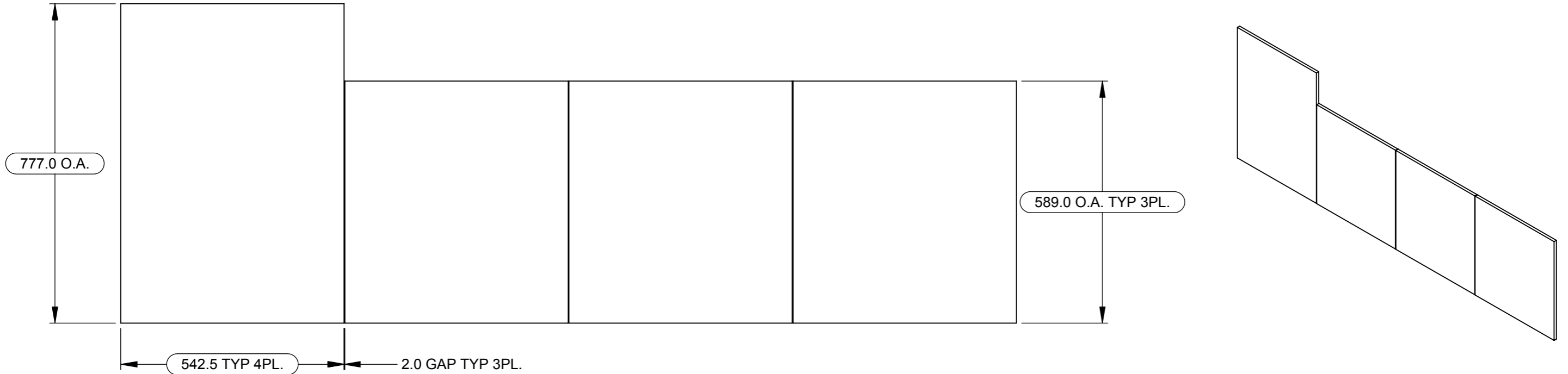

ALL DIMENSIONS IN MILLIMETRES UNLESS OTHERWISE SPECIFIED. GENERAL TOLERANCE: 0 DECIMAL (0) ± 0.5 ; 1 DECIMAL (0.0) ± 0.2 ; 2 DECIMALS (0.00) ± 0.1 ; ANGLES ± 0.5

DESCRIPTION						
SEPPELTSFIELD SHOWROOM						
DRAWN BY	DRAWN DATE	CLUSTER				
AG	10.09.13	DOORS, CPU SHELF, PRINT TRAY (CITTING SIZES)				
DO NOT SCALE DRAWING		SHEET	PAGE	SCALE	CODE	Rev
		A3	11 OF 13	1:20	N/A	1

NOTES:
 1. BALLOONED DIMENSIONS ARE CRITICAL INSPECTION DIMENSIONS
 2. DIMENSIONS IN PARENTHESIS ARE FOR REFERENCE ONLY (NON CRITICAL)
 3. ANY MODIFICATIONS FROM INITIAL APPROVED SAMPLE MUST BE SUBMITTED FOR APPROVAL
 4. DRAWING MUST BE APPROVED AND SIGNED PRIOR TO MANUFACTURE
 5. © THIS DRAWING IS OWNED BY AND IS ONLY TO BE USED WITH APPROVAL FROM UCI MANUFACTURING

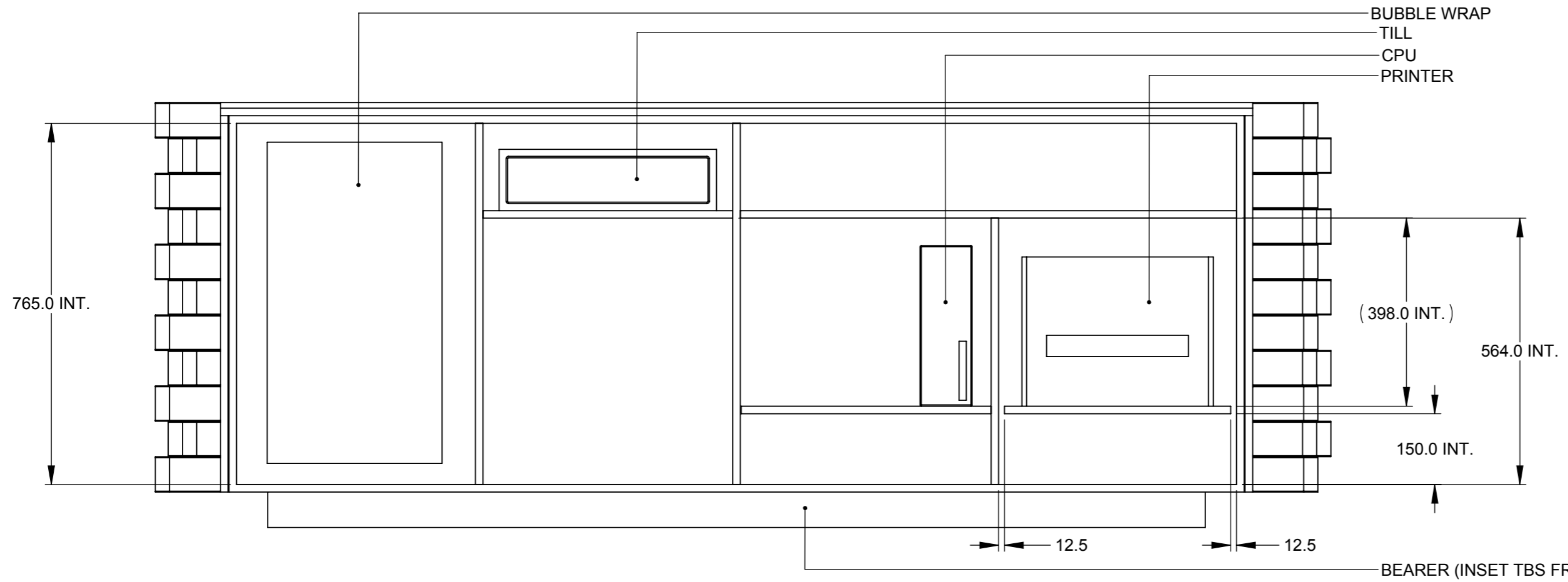
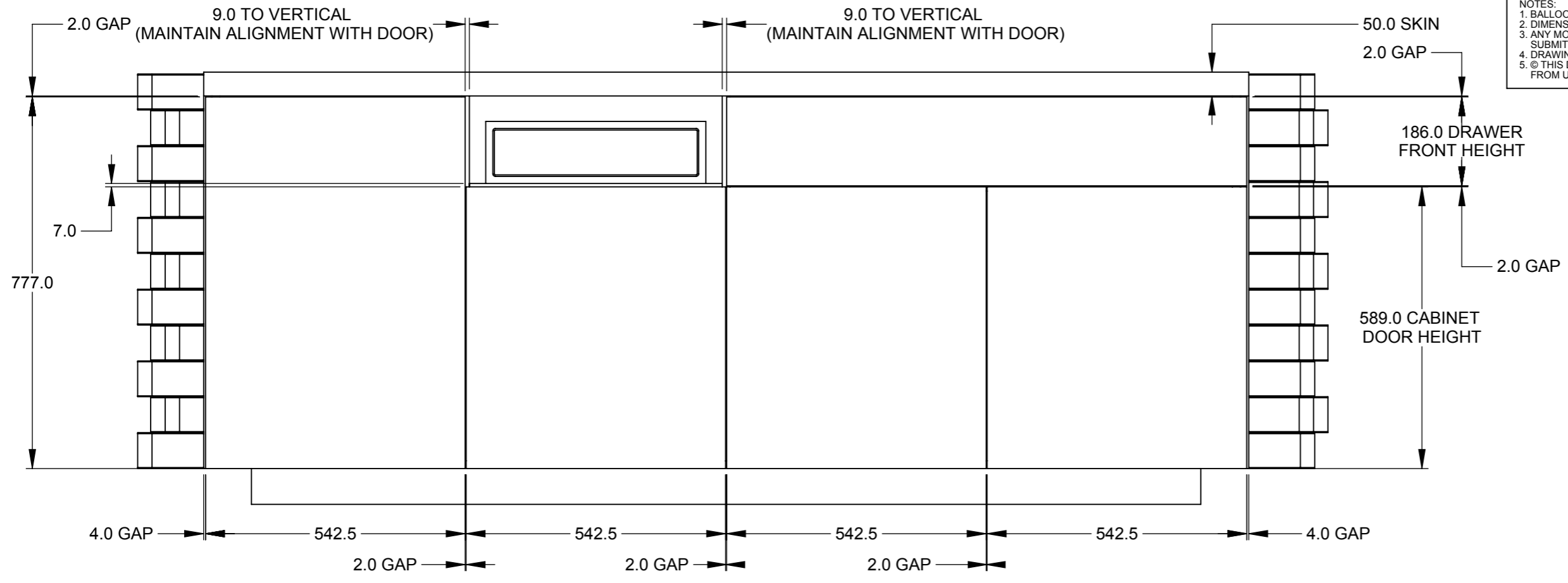

ALL DIMENSIONS IN MILLIMETRES UNLESS OTHERWISE SPECIFIED. GENERAL TOLERANCE: 0 DECIMAL (0) ±0.5; 1 DECIMAL (0.0) ±0.2; 2 DECIMALS (0.00) ±0.1; ANGLES ±0.5

DESCRIPTION						SEPPELTSFIELD SHOWROOM		
DRAWN BY	DRAWN DATE	CLUSTER						
AG	10.09.13	DOOR GAP ALLOWANCE + INTERNAL PLAN						
DO NOT SCALE DRAWING		SHEET	PAGE	SCALE	CODE	Rev		
		A3	12 OF 13	1:20	N/A	1		

NOTES:
 1. BALLOONED DIMENSIONS ARE CRITICAL INSPECTION DIMENSIONS
 2. DIMENSIONS IN PARENTHESIS ARE FOR REFERENCE ONLY (NON CRITICAL)
 3. ANY MODIFICATIONS FROM INITIAL APPROVED SAMPLE MUST BE SUBMITTED FOR APPROVAL
 4. DRAWING MUST BE APPROVED AND SIGNED PRIOR TO MANUFACTURE
 5. © THIS DRAWING IS OWNED BY AND IS ONLY TO BE USED WITH APPROVAL FROM UCI MANUFACTURING

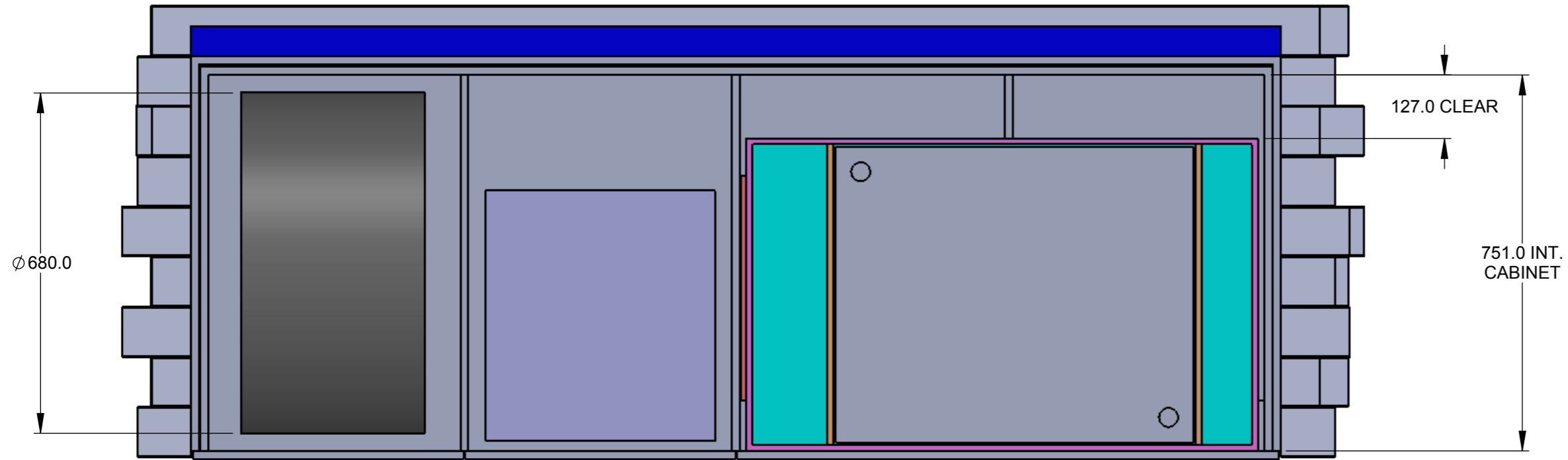

SECTION AT WRAPPING DRAWER HEIGHT

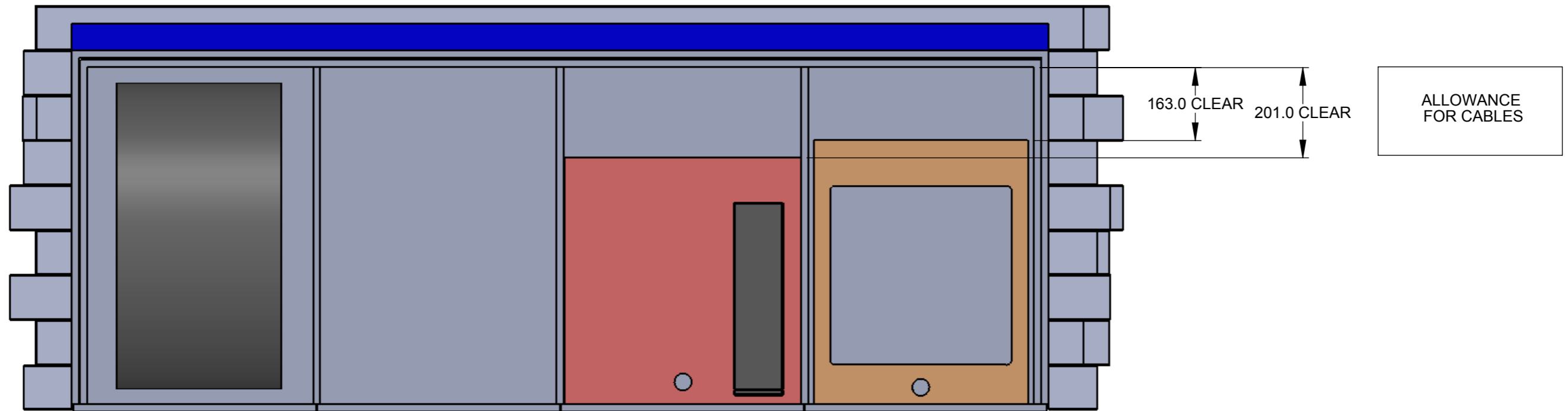

SECTION AT CPU SHELF HEIGHT

ALL DIMENSIONS IN MILLIMETRES UNLESS OTHERWISE SPECIFIED. GENERAL TOLERANCE: 0 DECIMAL (0) ±0.5; 1 DECIMAL (0.0) ±0.2; 2 DECIMALS (0.00) ±0.1; ANGLES ±0.5

DESCRIPTION SEPPELTSFIELD SHOWROOM						
DRAWN BY AG	DRAWN DATE 10.09.13	CLUSTER CABINET DEPTH ALLOWANCE				
DO NOT SCALE DRAWING		SHEET A3	PAGE 13 OF 13	SCALE 1:20	CODE N/A	Rev 1